

# Significance of General English in Air Traffic Controllers' Training Process

Adamanov Rustem  
Nemliy L.S. – associated professor of Aviation English  
Department  
Educational and Research Institute of Air Navigation, Electronics  
and Telecommunications  
National Aviation University  
Kyiv, Ukraine  
rustem.adamanov@gmail.com

**Abstract:** English is the language widely used by the aviation community, and is indeed a requirement for aviation professionals. Standard English is the basis of Aviation English language, so improving basic language skills shall be the first priority during training of air traffic controllers.

**Key words:** air traffic controller, Aviation English, General English, ICAO (International Civil Aviation Organization), research, Institute of Air Navigation, Electronics and Telecommunications National Aviation University.

## I Introduction

Everyone knows that Aviation English is de facto the international language of civil aviation. The proper level of its knowledge is an essential part of ATCo's work, however, General English, of course, is foundation that allows to succeed in this job. But how important is awareness of the language basic principles in training process? And how are the basic skills projected onto a future profession?

## II General English basic components

There are 4 main components in the area of Standard English foundation skills (according to Cambridge University):

1. Pronunciation
2. Vocabulary
3. Listening Comprehension
4. Grammatical structure

The main objective of any course aimed at English studying is to improve these aspects.

## III ICAO Language Proficiency Rating Scale

According to International Civil Aviation Organization language proficiency rating scale, there are 6 levels of English:

- 1) Pre-elementary
- 2) Elementary
- 3) Pre-Operational
- 4) **Operational**
- 5) Extended
- 6) Expert

ICAO scale takes into account the following aspects:

- Pronunciation
- Grammatical structure
- Vocabulary
- Fluency
- Comprehension
- Interactions

One can see that ICAO scale includes all the foundation skills mentioned before. It means that basic knowledge of language, which future air traffic controllers gain at a school/university, lay the foundation for their successful career.

## IV English in training process

Now it is obvious that studying English at a school/university greatly influences future specialists. I would like to analyze training process in the area of air traffic control through the prism education at National Aviation University. The following research will help to see the complete picture of the current situation.

This researched is based on results of external independent testing (subject: English) in the years 2013-2017. Unfortunately, there is no information regarding year 2014.

We can see that the average result of EIT in English for the last 5 years is 147,2. That is an awful result, however, since 2016 there is a tendency towards improvement. It means that higher educational institutions have great responsibility. They have to make a great effort to improve language skills of their enrollees.

## V Conclusions

Research: average level of English language skills among enrollees of the Institute of Air Navigation, Electronics and Telecommunications of National Aviation University (specialty: Air Traffic Controller)

To sum up, General English plays an important role in development of air traffic controllers. Results, which are shown before entering the university, are horrible. That is why higher educational institutions (especially aviation ones) are obliged to raise the level of their students' English rapidly in order to prepare high-qualified specialists.

## References

1. Doc 4444 – ATM/ 501. Air Traffic Management // ICAO, 2007. – 481 p.
2. <http://www.vstup.info> - all infographics are taken from Ukrainian base of enrollees
3. Doc 9835– AN/453. Manual on the Implementation of ICAO Language Proficiency // ICAO, 2004. –149 p. (in Russian).

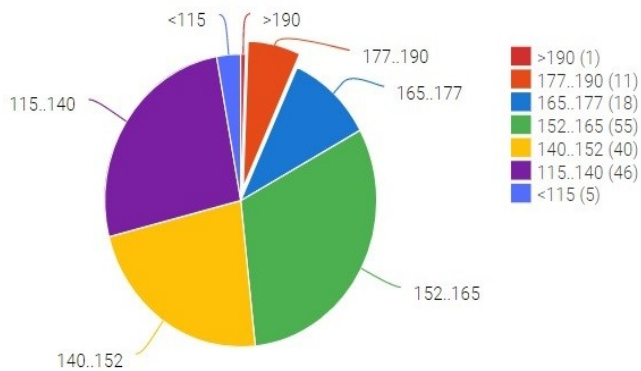
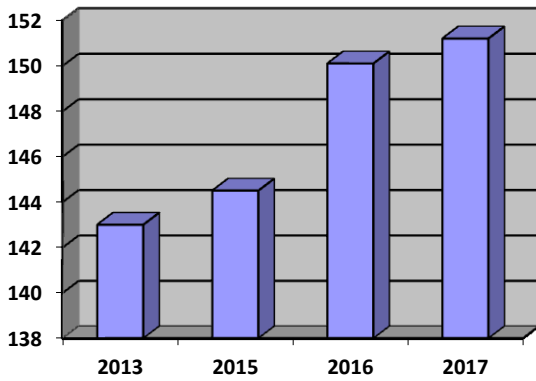

# Studying English for Specific Purposes

## Telecommunications

Viktoriia Avramenko

Academic and Research Institute of Air-navigation,  
Electronics, and Telecommunications  
National Aviation University  
Kyiv, Ukraine  
awramenko20@gmail.com

Tetiana Dekalo

Academic and Research Institute of Air-navigation,  
Electronics, and Telecommunications  
National Aviation University  
Kyiv, Ukraine  
tdekalo2@gmail.com

**Abstract**— *Specialists from different countries use English both to exchange experience and communicate. ESP has become a priority that helps students to apply what they learn during studying English to their own field of study, whether it be electronics, telecommunications, computer science. The paper presents importance of English for future telecommunications professionals.*

**Keywords** —*English for Specific Purpose; telecommunications; specialists; studying; vocabulary.*

### I. INTRODUCTION

English has become the main source of technical progress as it enables rapid exchange of information and research of the common global problems. Specialists from different countries use English to share or exchange information, consequently the study of the English language is a priority nowadays. ESP (English for Specific Purposes) combines the acquisition of specific information and the development of language skills [1].

### II. THE FIELD OF TELECOMMUNICATIONS AND SPECIFICS OF THE LANGUAGE

The telecommunications industry has truly become an interdisciplinary field of knowledge, combining computer science and electrical engineering disciplines. It is obvious that the content of the area of telecommunications is marked by a diverging and ever-increasing number of disciplines. Networking professionals and communications specialists in today's information society require knowledge in numerous areas: computer engineering, information management, telecommunications networking, wireless communication, satellite, radio, TV, to name a few.

Students need English in their course of study and for their future professional occupation. There are many foreign companies where all employees are required to possess a certain level of English proficiency besides the requirement for being able to readily apply technology from several disciplines in order to seek innovative solutions to the full range of telecommunications needs. Therefore future specialists need to be able to deal with a variety of subjects using English as a primary tool and to perform well in negotiating contracts, participating in meetings and

discussions, explaining technological developments and new products, attending social/professional events, making presentations, reading academic/professional journals, attending professional conferences, writing business communication [2].

### III. TELECOMMUNICATIONS VOCABULARY

Practically all telecommunication terms are written in English and are constantly updated. Telecommunications is a specialized field that has a language of its own. It is still English, but many telecommunications vocabulary words have meanings different from what we are familiar with.

For example:

*a) Frame* – a rack to which telecommunications equipment is mounted [3].

*b) Firewall* – a part of a computer system or network that is designed to block unauthorized access while permitting authorized communications [3].

*a) Plant* – a general term for all equipment used by a telephone company to provide telecommunications services [3].

ESP vocabulary can be practised and consolidated by similar methods and techniques used for practising and consolidation of general vocabulary. Writing tasks can include reports and different instructions for various devices and technologies, making summaries from technical journals, describing processes and techniques, labelling diagrams and pictures, describing graphs and comments on charts etc. [4].

### IV. CONCLUSIONS

The ESP is a priority for telecommunications sphere. The future specialists should know that it is not enough to have professional knowledge in a certain field [5]. In many cases communication is the key for success or failure. As specialists, they need to be able to deal with a variety of subjects, to communicate, to exchange or share information with other specialists from different countries. Dealing with a variety of subjects they have to use English as a primary tool and perform well in negotiating contracts, explaining technological

developments and new products, attending professional events.

#### REFERENCES

- [1] Harding, K. (2007). English for Specific Purposes. Oxford University Press.
- [2] Dora Blagova “English for Telecommunications – Problems and Possible Solutions”, [www.beta-iatefl.org](http://www.beta-iatefl.org)
- [3] Telecom Terms and Acronyms You Should Know, <http://www.vividfuture.org>
- [4] 15 Information Technology Vocabulary Words Every English Student Should Know, <https://www.fluentu.com>
- [5] Eguchi, M. and Eguchi, K. 2006. The Limited Effect of PBL on EFL Learners: A Case Study of English Magazine Projects, Asian ESL Journal, Volume 8. Issue 3.

# The Problems of Aircraft Centering

Oleksiy Babychuk

scientific adviser: Nataliia Zelinska

Aviation English department,

Educational and Research Institute of Air Navigation,

Electronics and Telecommunications,

National Aviation University,

Kyiv, Ukraine

[ax.babychuk43@gmail.com](mailto:ax.babychuk43@gmail.com)

Dmytro Piatrin

scientific adviser: Nataliia Zelinska

Aviation English department,

Educational and Research Institute of Air Navigation,

Electronics and Telecommunications,

National Aviation University,

Kyiv, Ukraine

**Abstract - the work is devoted to consideration of the problem of improving the safety of aircraft flight. The paper proposes methods for optimal centering of aircraft. Also, the main aspects of plane alignment are considered in this paper.**

**Keywords - aircraft centration; flight safety; center of gravity.**

## INTRODUCTION

In the modern world, when almost every month there are reports of aviation catastrophes in different parts of the world, the professions, from which the safety of the flights directly or indirectly depends, acquire special significance. In addition to the professionalism of pilots and technical service, safety of flight is also other components. Among the terrestrial technical service there is such a unique profession as the traffic controller of aircraft centering, which plays an invaluable role in providing security. A specially trained professional controls the loading and refueling of the aircraft so that the center of gravity does not go beyond the permissible limits, thereby regulating the centering characteristics of the aircraft: center of gravity and centering.

Any aircraft that ascends into the air, in addition to high flight-tactical data, must be balanced, stable and manageable. In the optimal combination of these three factors, the main role is played by: 1. Position of the center of gravity of the aircraft; 2. Centering the aircraft.

The center of gravity is the main indicator of the alignment of the aircraft. The location of the center of gravity of the aircraft determines the balancing, stability and controllability of the aircraft on the ground and especially in the air, that is, the degree of flight safety.

## EASE OF USE

When the number of passengers and cargo changes or when the aircraft's flight weight decreases because of fuel burnout, the position of the center of gravity changes, and the plane's alignment also changes. When the cargo is placed in the front part of the aircraft, the centering becomes extremely forward, and vice versa, the placement of cargo in the tail part shifts the centering backwards, making it extremely rear.

Front centering is threatened by the fact that the aircraft begins to nod and is difficult to control; there are problems with the overall fuel inefficiency. Extremely rear centering lifts the nose of the aircraft, it flies unstably, its stability in flight is violated.

The rear centering is extremely dangerous during taking off, and the front one is dangerous during the landing.

## MAIN PART

The solution to the problem is based on the ensuring a reliable centering of the aircraft by ensuring reliable switching on and off position of the transfer pumps and reliability of the control means thereof.

In order to solve this problem, in the method of plane alignment, which includes alternating full or partial production of fuel from the fuel compartments of the airframe, accompanied by the transfer of fuel to the delivery compartment during the consumption of fuel from the propulsion engine. According to the invention, the transfer of fuel into the fuel supply compartment from other fuel compartments, except for the post-current-balancing one. It is conducted through a pre-consumption fuel compartment adjacent to the consumption compartment along its rear wall with continuous supply of power to the drive of the transfer pump. During the entire flight fuel transfer from the post-balancing fuel compartment lead directly to the delivery compartment after the fuel level in it is lowered, signaling the end of fuel production from other compartments.

In order to accomplish the same task, a control system for fuel production on an airplane, comprising means for switching on and off the drives of pumps. It alternately produces fuel and transfers it to the consumption compartment from other sections. According to the invention of the device for activating the hydraulic drives of pumps pumping into the fuel consumption chamber is coming from all other compartments. They are made in the form of pipelines connecting the hydraulic drive of each of these pumps directly to the output of a centrifugal fuel pump high pressure having driven by the main engine of the aircraft.

## CONCLUSIONS

The methods for improving the safety of the aircraft by eliminating the problem of centering the aircraft are proposed in the paper. These methods can potentially save a significant number of human lives.

## REFERENCES

- [1] <http://www.findpatent.ru/patent/214/2140377.html>
- [2] <https://studfiles.net/preview/4080731/page:13/>
- [3] [https://www.profguide.ru/professions/dispatcher\\_po\\_centrovke\\_samoletov](https://www.profguide.ru/professions/dispatcher_po_centrovke_samoletov)

# Plain language and standart phraseology in air traffic control

Lyudmyla Nemliy,  
a doctor of Philosophy, associated professor of  
Aviation English Language Department  
National Aviation University  
Kyiv, Ukraine  
[nemliy\\_mila@ukr.net](mailto:nemliy_mila@ukr.net)

Diana Sukhanova, Baidin Denys, Bozhuk Bogdan students  
Scientific and Research Institute of airnavigation,  
electronics and telecommunication  
National Aviation University  
Kyiv, Ukraine  
[sukhanova.diana98@gmail.com](mailto:sukhanova.diana98@gmail.com)

**Abstract** – The use of and standard phraseology by pilots and air traffic controllers is necessary for safe flight operations while plain language, or non-standard phraseology, can lead to misunderstanding, break down of the communication process and eventually to loss of contact. The primary objective of communication in ATC is to control the quality of speech including speed of delivery and clarity, and compliance with the requirement of using standard phraseology.

**Keywords** — plain English, standart phraseology, pilot, controllers

## INTRODUCTION

Many factors influence the process of ATC and pilots communication, phraseology is the most important, because it allows us to communicate rapidly and effectively despite differences in language and reduces the opportunity for misunderstanding. The need for clear communication between pilots and ATC is vital in assisting the safe and faster operation of aircraft movement. Therefore, it is important that regards are given to the use of standard words and phrases and that all involved ensure that they maintain the highest professional phraseology standards at all times..

## PLAIN ENGLISH AND STANDARD PHRASEOLOGY

ATC community captured situations where the usage of non-standard phraseology resulted in misunderstanding and confusion by flight crew. The investigation of several episodes revealed that definite ATC clearances or instructions have been misheard and incorrectly read back by the flight crew some of which have not been challenged by ATC. ATC communications shall be delivered to flight crew in a clear, concise, efficient and unambiguous manner. Standard phraseology shall be used in all situations for which it has been specified. Plain language shall be used only when standardized phraseology cannot assist an intended transmission. It is not possible to provide phraseologies to cover every situation which may occur; however if standard phrases are adhered to, any possible doubt will be reduced to a minimum. The International Civil Aviation Organization (ICAO) new English language

requirements suggest usage of plain English when standard phraseology is not enough to solve an emergency situation. So, both plain English and standard phraseology should be practice during future ATC training process.

Aviation English training is a very young field. Although some aviation specialists have been working in the field for a couple of decades, and a number of aviation English programs which have existed, the absence of an ICAO Standard requiring a specific level of Aviation English training has meant that the industry has been unable to invest resources into full fledged development efforts. ICAO Doc 9835 defines that the ICAO standardized phraseology is used in all situations for which it has been defined. And in case standardized phraseology is not enough for successful communication the plain language is used. The aim of the ICAO standard phraseology is to cover routine and non routine situations. However, the prescribed phraseology cannot predict all possible spoken communicative intention, plain English would be in use.

Concerning over the importance of English in aviation during emergency situations we must say that ATC needs to have an operational level of English language. It means that ATC would deal in emergency situation effectively.

Thus, English language classes of ATCs must be interactive ones, including communicative exercises, role games and others activities which would help to develop language speaking skills and psychology reaction, quick thinking.

## CONCLUSIONS

Aviation is a very difficult mechanism which consists of many parts all aviators who must work without any mistake. Proper communication between pilots and ATC is very important for keeping passengers safety and it is a very important part of aviation structure, so without it there could be confusion in operation and service.

## REFERENCES

1. Doc 9835– AN/453. Manual on the Implementation of ICAO Language Proficiency
2. Doc 9432 – AN/ 925. Manual of Radiotelephony // ICAO, 2007.
3. ICAO Doc 943

# The Problem of Reducing Aircraft Weight

Vladyslav Benko  
scientific adviser: Ntaliia Zelinska  
Aviation English department,  
Educational and Research Institute of Air Navigation, Electronics and Telecommunications,  
National Aviation University,  
Kyiv, Ukraine  
[vladbenko60@gmail.com](mailto:vladbenko60@gmail.com)

*Abstract—the paper is devoted to consideration of the aircraft weight reducing problem. The paper proposes a method for revision of unbranched parts of an aircraft. Also, the ways of replacing the batteries for more modern ones and the use of a greater number of composite elements for the aircraft design are considered in the paper.*

*Keywords—airplane weight; aircraft weight reduction; composite materials.*

## I. INTRODUCTION

An inalienable technical requirement for any product of the aviation industry is the reduction in the weight of the product. It is important to note that weight reduction is a problem that designers and designers solve constantly, trying to minimize the mass of the aircraft as much as possible, lifted into the air. More than 80% of the weight of a fully loaded commercial airliner is the hull and its fuel, and not the passengers and their luggage. The reduction in weight by only 1% gives a fuel economy of 0.75%. That is, the economic benefit of reducing the weight of the aircraft is obvious. [1]

Moreover, with fuel economy, the amount of carbon dioxide emissions is reduced, which has a positive impact on the environment.

## II. MAIN PART

One way to solve this problem is to perform an audit of loose things on the plane. Employees of Airberlin carried out such a check on the Airbus A330. During the audit, unpinned items weighing 630 kg were recovered. As a result, the following conclusions were reached: 17 kg can be cleaned without any harm to the aircraft, objects weighing 116 kg can be replaced with lighter analogues, the remaining 492 kg remain unchanged. [2]

Another way to reduce the weight of the aircraft was proposed by Boeing. Its essence lies in the use of modern batteries. [2] When using batteries with more energy-efficient elements, the total weight will be less in comparison with old analogues at the same capacity. [3]

The third solution to this problem is the use of composite and polymer materials in the aircraft fuselage design. The development of aircraft construction is associated with a continuous struggle to reduce the weight of the airframe. Reducing the weight of the structure can be achieved by rational choice of materials and power schemes, the use of rational technological processes, and also by specifying the loads acting on the structure. [5]

With the reduction in the weight of the structure due to the use of composite materials, the economic efficiency of the aircraft is increased. The use of polymer composite materials in the power part of the airframe design allows not only to reduce the weight of the airframe, but also to increase its aerodynamic perfection. The growth of aerodynamic quality and cruising Mach number is provided due to optimal values of the wing design parameters, that is, the elongation, sweep and relative thickness of its profile, which is unattainable for the metal structure.

Thus, for aluminum with an elongation  $\lambda = 9 \sim 10$  (Tu-204, Boeing 737, Airbus A320 ...), aluminum is used with an elastic modulus of  $E = 72$  GPa. For a wing with an elongation  $\lambda = 11 \sim 12$ , the use of aluminum leads to an additional increase in weight due to the need to increase the flexural rigidity of the wing. This is why a material with a large modulus of elasticity should be used for a wing with an elongation  $\lambda > 10$ . Carbon plastic allows obtaining the necessary rigidity of the wings due to a greater modulus of elasticity  $E > 100$  GPa (for the finished structure). [6]

The share of the use of composite materials in the construction of modern long-distance aircraft reaches 50%. For example, on Boeing 787 Dreamliner and Airbus A350 aircraft, composite materials are used in the design of a wing, a center wing section, a fuselage and a tail unit. Nevertheless, this is not the limit and increasing the number of composite parts can significantly reduce the weight of the aircraft.

### III. CONCLUSIONS

The paper proposes a method for conducting an audit of the aircraft's loose things. This method will get rid of excess cargo, respectively, reduce the mass. A method for replacing the batteries with more modern ones is also proposed. This method will allow reducing the space occupied by accumulators, in turn making room for other components of the aircraft.

The last method offered in this paper proposes to increase the number of composite elements of the fuselage

design. This method contributes to the most significant reduction in the mass of the aircraft.

### REFERENCES

- [1] <https://proektoria.online/projects/snizhenie-obshhej-massy-samoleta/>
- [2] <https://wek.ru/airberlin-primumala-kak-umenshit-ves-samoleta>
- [3] <http://aviaglobus.ru/2013/01/23/5319/>
- [4] <https://www.popmech.ru/technologies/5711-avialayner-boeing-787-dreamliner/>
- [5] Одинок Ю.Г. Расчет самолета на прочность: Учебное пособие. М.: Машиностроение, 1973г. -392 с.
- [6] Солошенко В. Композиты в авиастроении. Опыт применения. Линия полета – 2013, № 82.



# Possible difficulties that a student of a technical specialty may experience while studying English

Berezhna Olena  
Department of telecommunication systems,  
Educational and Scientific Institute of Aeronavigation,  
Electronics and Telecommunications,  
National Aviation University  
Kyiv, Ukraine  
thealmightyelena@gmail.com

Zhugan Julia  
Department of telecommunication systems,  
Educational and Scientific Institute of Aeronavigation,  
Electronics and Telecommunications,  
National Aviation University  
Kyiv, Ukraine  
zhugyulia@gmail.com

Romanova Anna  
Department of telecommunication systems,  
Educational and Scientific Institute of Aeronavigation,  
Electronics and Telecommunications,  
National Aviation University  
Kyiv, Ukraine  
annieromanova22@gmail.com

*Abstract - The main features of studying a foreign language by students of technical universities are considered. This article describes the process of learning English in the technical universities and the main problems students can face with while learning a foreign language. It also emphasizes the main reasons for studying English by telecommunications students.*

*Keywords problems connected to studying foreign languages, English in technical specialties, the importance of English for telecommunications students.*

## I. INTRODUCTION

Nowadays no one doubts the importance of knowing English. Every year more and more employers give priority to hiring those specialists who have professional skills in using a technical foreign language, so it is important to realize the advantages of its studying.

The active use of foreign languages in professional activity of future engineers is one of the main perspectives nowadays. For such technical specialties as the engineer of telecommunication systems, it is common to study specific terms in English, as well as solving tasks related to the translation of technical documentation. Here are the main difficulties that a student of telecommunications may face in the process of getting higher education in the chosen specialty.

## II. LACK OF MOTIVATION IN STUDYING ENGLISH

One of the main problems an English teacher can face with while working with students of a technical specialty is their lack of motivation for learning a language. Students of

technical universities often refer a foreign language to "secondary" disciplines and therefore do not give it enough attention. After prioritizing some of the disciplines, students often show the intellectual passivity when learning English, which ultimately affects the level of knowledge of a foreign language.

## III. DIFFERENT KNOWLEDGE LEVEL OF STUDENTS IN ONE GROUP

Working in heterogeneous groups is a great challenge - both for the teacher and for the students. It is assumed that the students have received the basic knowledge in school. Unfortunately, practice shows that the situation is slightly different. First-year students, who entered the university to get a technical specialization, have different levels of knowledge in a foreign language. Later they all end up in one group, where many students sooner or later start to lose interest in learning the language - some of them because it's all too complicated and hard for them, others - because of the fact that they have already known that material and eventually get bored.

One of the possible ways out of this situation is the organization of differentiated education, taking into account the characteristics of heterogeneous groups, the development of curricula and new methods aimed at effectively solving the problems of different-level groups.

## IV. THE LACK OF TEACHING HOURS IN THE CURRICULUM

The next issue is the extremely limited amount of academic hours devoted to language studying. It is worth mentioning this problem especially in those conditions when,

thanks to the development of the Internet network, the professional studying of specialists has become mostly bilingual. On our opinion it is necessary to establish the necessary number of hours as well as to allow three-level division of groups.

#### V. THE LACK OF UKRAINIAN ANALOGUES OF TRAINING MATERIALS

There is an important problem for technical universities which is connected to the absence of the foreign language textbooks for technical specialties. Those educational materials that are nowadays offered to students, are developed mostly for economical specialties, and obviously they cannot be used for the educational purposes of the telecommunication engineers-to-be. The textbook market is vast and has plenty of various teaching materials, especially the foreign ones, which are focused on developing the students' communicative skills and leading them to study a professionally oriented foreign language. But it should be mentioned that the analysis of all these manuals and testing them in the teaching process showed that these benefits do not match the goals which are set by the universities in Ukraine.

#### VI. THE ROLE OF THE TEACHER IN MOTIVATING THE STUDENT

The successful process of learning English depends not only on the abilities of the student. An important role is played by the influence of the teacher. That is why the main task of the teacher and a lecturer at first is to recognize the student's language training level and to help him with organizing a further process of studying a foreign language. Therea differentiated approach will help students and also it is

important to take into account their preferred cognitive strategies [3].

#### VII. CONCLUSION

Summarizing all of the above, it can be said that the specificity of teaching a foreign language is quite complex and multifaceted. At today's stage of the educational development it is impossible to facilitate the process of learning English for the students of telecommunications without their previous knowledge base. If the process of training in learning foreign languages starts sooner than entering the university in a form of creative tasks that stimulate the activity of students, the use of the role-playing methods, project assignments, discussions of different topics, the vocabulary replenishment etc., then it will be much easier to focus on the studying of technical English since the very beginning of educational process of students in universities.

#### REFERENCES

1. Zimnyaya I. A. Lingvopsikhologiya rechevoy deyatel'nosti [Linguistic psychology of speech activity] M.: MPSI; Voronezh: MODEK, 2001. 432 p.
2. Yakunin V. A., Meshkov N. I. Psikhologo-pedagogicheskiye faktory uchebnoy uspeshnosti studentov [Psychological and pedagogical factors of students' academic success] Vestnik LGU, Saint Petersburg. 1980, № 11.
3. Kaznacheyeva S. N. Studencheskiy vozrast i organizatsiya poznavatel'noy deyatel'nosti: daydzhest [Student age and organization of cognitive activity: digest] Psychology of training. , 2007, № 5.

# Methods of Radioelectronic Equipment Reliability Calculation

Bevz O.I.

Scientific advisor: Zuiiev O.V., PhD, Associate Prof.  
Aviation Radioelectronic Complexes Department,  
Educational & Research Institute of Air Navigation, Electronics and Telecommunications  
National Aviation University,  
Kyiv, Ukraine  
[elenabevz1995@gmail.com](mailto:elenabevz1995@gmail.com)

Sinevolnova A.A.

Scientific advisor: Zuiiev O.V., PhD, Associate Prof.  
Aviation Radioelectronic Complexes Department,  
Educational & Research Institute of Air Navigation, Electronics and Telecommunications  
National Aviation University,  
Kyiv, Ukraine  
[sinevolnovaa@gmail.com](mailto:sinevolnovaa@gmail.com)

**Annotation** — the work is devoted to consideration of the problem of increasing the reliability of radioelectronic equipment. In work are proposed several methods of calculating the reliability indices of certain types of equipment. Also considered in the use of equipment redundancy to improve reliability.

**Keywords** — radioelectronic equipment, reliability, quantitative reliability indicators, methods for calculating reliability, equipment redundancy.

## 1 INTRODUCTION

To estimate the effectiveness of Radioelectronic Equipment (REE) in one or another system of practical use it is necessary to know not only the indexes and effectiveness criteria but also correlations, models that adequately describe the dynamics of REE technical condition change in terms the required REE reliability characteristics [1; 2; 3]. Talking about the REE reliability characteristics, the dynamics of failures stream is meant.

Reliability calculation is a process of obtaining set numerical indexes [1; 2]. According to the technology of reliability indexes (RI) numerical obtaining we can separate the following three groups of methods:

1. Analytical.
2. Research-experimental.
3. Methods that based on simulation modelling by electronic computers (EC).

By the first group, using analytical methods, we obtain calculation relations, formulas and carry out calculations. It's necessary to know density of probabilities distribution (DPD) of mean operating time between failures, DPD of restoration durations or the moments of these DPD as well as REE schemes in terms of reliability, operation conditions, REE and its separate units modes of operation etc.

Methods of the second group are based on carrying out specially organized experiments on the constructing stage and during the process of operation. Statistical data are collected and processed.

For the third group of methods special EC programs are developed, with the help of which one can generate random values (RV) of mean operating time between failures, RV of REE restoration time, operation conditions, actions of personnel etc. A large series of events, realizations forming a complete group of events is modelled. Then RI and REE effectiveness is estimated.

## 2 PROBLEM STATEMENT

Let's consider analytical methods. These methods are classified by the accounts taken of operation factors, detailing degree of REE in terms of reliability, taking into account of REE restorationability etc.

We can name the following methods: admissible reliability calculation; approximate reliability calculation; reliability calculation taking into account elements parameters tolerance (correlation method of a reliability calculation) etc.

The purpose of the further REE practical investigation is determination of numerical values of restorable objects RI, application of approximate and complete methods of reliability calculations, solving the problem of comparative analysis of the REE redundancy options reliability.

To achieve REE investigation goals it is necessary to solve the following main problems:

1. To calculate numerical values of RI for the main restorable object using approximate and complete methods of object reliability calculations and also to determine anticipated average total expenses for the repair for a given time interval and assess the alternation of this indices values

on conditions of taking and non-taking into account the terms of object operation.

2. To solve the problem of increasing the investigated object reliability on the base of redundancy of some of its elements and perform the comparative analysis of object redundancy results by means of efficiency technical and economic criterion.

3. For the most effective method of the investigated object redundancy, calculate numerical values of reliability indexes and to draw the graphs of object reliability probability with its elements redundancy and without it.

### 3 BASIC PART

Some general assumptions are made for approximate and complete methods of object reliability calculations and a series of stages is realized, specified for each method. Assumptions during calculations: connection of elements in an object is basic and consequential in terms of reliability (a failure of one element causes a failure of the whole object); the failure rates of elements  $\lambda_i(t) = \text{const}$  and doesn't depend on time, that is the law of distribution of mean operating time between separate elements failures is exponential; failures of elements are independent events.

Stages of reliability calculation: a list of failures and symptoms of their manifestation in REE is formed; basic elements (failure of which causes a REE failure) are determined; object elements are divided into groups with relatively equal failure rates and then the quantity of elements in group is counted up; in accordance with reference books average failure rates values  $\lambda_{0i}$  are determined for each group elements under normal conditions and the range of value changing  $\lambda_{0i} - \lambda_{0\min} \dots \lambda_{0\max}$ ; operating modes of object elements in electric schemes and operating conditions of a whole object (humidity, pressure, vibrations etc.) are specified.

Approximate method of reliability calculation. Calculation of survival probability  $P_{RED}(t)$  and mean operating time between failures  $T_{0RED}$  is fulfilled by the formulas:

$$P_{RED}(t) = \exp(-\Lambda_{RED/norm} t); \quad (1)$$

$$T_{0RED} = \frac{1}{\Lambda_{RED/norm}}; \quad (2)$$

$$\Lambda_{RED/norm} = \sum_{i=1}^k n_i \lambda_{0i}; \quad (3)$$

where  $\Lambda_{RED/norm}$  is summary failure rate of elements in normal operation conditions;  $k$  is the general number of elements groups in an object. Usually they are separate types of RC (resistors, capacitors, ships etc.);  $n_i$  is the number elements of the  $i$ -th group elements;  $\lambda_{0i}$  is the mean value of the  $i$ -th group of elements failure rate in normal operation conditions.

When making calculations using formulas (1), (2), (3) we may find  $P_{RED/\min}(t)$  and  $P_{RED/\max}(t)$ , if boundary values  $\lambda_{0\min}$  and  $\lambda_{0\max}$  are known.

Complete reliability calculation. This method differs from the previous one by the fact that it takes into account the influence of operation conditions on REE reliability.  $P_{RED}(t)$  and  $T_{0RED}$  are calculated by formulas:

$$P_{RED}(t) = \exp(-\Lambda_{RED}(\vec{\alpha}_l)t);$$

$$\Lambda_{RED}(\vec{\alpha}_l) = \Lambda_{RED/norm} \left( \prod_{j=1}^l \alpha_j \right),$$

$$T_{0RED} = (\Lambda_{RED}(\vec{\alpha}_l))^{-1},$$

where  $\Lambda_{RED/norm}$  is summary objects failure rate under normal operation conditions;  $\alpha_j$  is the correction factor, taking into consideration operation conditions of the whole object and its separate parts (e.g.,  $\alpha_1$  — humidity,  $\alpha_2$  — pressure,  $\alpha_3$  — vibrations,  $\alpha_4$  — objects elements electric load coefficient etc.);  $l$  — the number of operation conditions taken into consideration.

Work [2] contains tables with correction coefficients  $\alpha_j$  taking account of the influence of objects operation conditions on their reliability. This influence is expressed in the change in failure rate of elements taken under normal conditions. As usual,  $\alpha_j \geq 1$ , then failure rate  $\Lambda_{RED}(\vec{\alpha}_l)$  increases, while REE reliability decreases. Work [2] also contains graphs, taking into consideration electric load effect upon RC failure rate.

Thus, one should estimate operation conditions effect at least at two stages, at least: first of all at the level of electrical scheme, then — at the whole object's level. Calculation of availability function for the restorable object. It is known, that for any distribution law restorable objects' availability function is determined in such a way:

$$K_{av} = \frac{T_0}{T_0 + T_{rs}},$$

where  $T_0$ ,  $T_{rs}$  are MTBF and mean restoring time of REE serviceability.

### 4 CONCLUSIONS

In work considers the methods for calculating the quantitative reliability indices of REE. Can determined list of methods it is suggested to use analytical methods of calculation of reliability. These methods are supposed to be used for comparative analysis of reserving options for REE. Indicative and polarimetric angle measuring method for determining the coordinates of the PS.

### LIST OF REFERENCES

- [1] Dhillon B.S. "Maintainability, maintenance, and reliability for engineers". New York: Taylor & Francis Group, 2006, 214 p.
- [2] Zuiev O.V., Solomentsev O.V., Khmelko Ju.M.. "Basics of Radioelectronic Equipment Reliability, Operation and Repair Theory": Lecture synopsis. — Kyiv.: NAU, 2011 — 60 p.
- [3] Новиков В.С. "Техническая эксплуатация авиационного радиоэлектронного оборудования": Учебник. М.: Транспорт, 1987. - 261 с.

# Aircraft Noise Reduction

Ekrem Eken

scientific adviser: Nataliia Zelinska

Aviation English department,

Educational and Research Institute of Air Navigation, Electronics and Telecommunications,

National Aviation University,

Kyiv, Ukraine

[Peripella89@gmail.com](mailto:Peripella89@gmail.com)

**Abstract**—the paper is dedicated to solving problem of noise from the aircraft, which disturbs people living near the airports. In this work the solutions for this problem are proposed. The examples given are from real life. They are also time proved.

**Keywords**—aircraft noise pollution; airport operation; jet engine; jet blast; aircraft design.

## 1 INTRODUCTION

[1] Increasing the prevalence of air transport, the emergence of new brands powerful aircraft. convergence of residential areas with territories airports and location of residential neighborhoods under routes flown aircraft leads to increase in noisy areas. As a consequence, an increasing number of people living in uncomfortable acoustic conditions. Acting as stress stimulus, interfering with work, school, leisure, communication, sleep, noise causes stress, overexertion and fatigue (stall) adaptation mechanisms, n can provoke somatic and neuropsychiatric syndromes and diseases.

## 2 THE PROBLEM

The analysis of the results during the tests turned out that the aerodynamic noise of aircraft was significantly reduced. Modern cities are constantly growing. The area is expanding and airports that were formerly on semi-urban territories, become part of them. It resulted in soaring and coming on a landing aircraft deliver considerable inconvenience to the inhabitants of the city. Especially if a bedroom suburb appears near the airport. International aviation service regularly put forward new requirements regarding aircraft noise level that can become a serious problem for some air carriers. Reduction of noise from aircraft reduces airport noise naturally. To resolve this problem, building companies around the world are trying to develop new technologies too.

## 3 MAIN PART

[2] Because the noise is mainly produced by engines, most attention in the work is given to him. A large proportion of the noise is made by the jet blast. So the nozzle jet engines make corrugated and generate them. Reduce turbulence and noise respectively jets allow chevrons like-shaped nozzles on the cut. If the air inlet make an oblique to its lower part

protrudes forward, the sound wave from the fan goes up and does not reach land. Another way to reduce engine noise was the widespread use of so-called sound-absorbing constructions (CLP). Today, their development is an independent field of acoustics.

[3] The Japanese Agency for research in the field of aviation and cosmonautics has developed special modifications for landing gear, shutters and flaps of aircraft, which will significantly reduce noise during landing.

To resolve this problem, aircraft design companies around the world are trying to develop new technologies.

New development of Japanese represents additional elements for the landing gear and the edge of the aircraft wing flaps. Due to the fact that these plugs will close the gap between the components, will improve the flow chassis airflow. Lining the bottom of the flaps is able to reduce the chance of formation of turbulent airflow. In addition, additions in the upper part of the flap is equipped with vortex generators. Thanks to this modification will be disturbed laminar flow, thus prevented the formation of a boundary layer air mass with a slow speed. In addition, modification of the flap serves to decrease gaps between their edges and the wing of the aircraft. Lining will slightly improve the aerodynamics of the ailerons, they also contribute to a decrease in the angle of their output, not affecting the overall efficiency of the wings. Such modification has been tested in October 2016 onwards. Test results showed significant efficacy of such developments in noise reduction. The pads were finalized. Now their size is smaller and the number of vortex generator on the contrary increased, also changed their form. The new version has been tested on the Cessna Citation Sovereign. Prototype Japanese researchers named Hisho, "Secretary". Test flights were conducted from September to October 2017 onwards. According to the results of 17 flights and 222 measurements, it became known that the volume of aerodynamic noise reduced at 3 DB, and the noise from the chassis became the 4 lower decibel. That means that the overall noise level aircraft emissions can be reduced at least 4 DB. To make the aircraft even quieter, there is a need to develop an entirely new aircraft engines, since they are the main source of noise.

[4] We can use solutions such as:

Rational location of runways;

Reduce the number of flights due to heavy current models;

The use of less noisy planes;

To apply special techniques during takeoff and landing to reduce noise;

The reduction in the number of flights because of the heavy modern models liners;

An optimal regulation of the operation of the engine and airspeed to increase the height of the expectations and pre-maneuver;

The approach by the method of continuous decline;

The angle of the glide path increasing;

The reduction of aircraft braking;

The use of two-segment glide path;

Reduction of aircraft use with a variable aerodynamic configuration;

The change of flight routes;

Night and training flights limitations;

The restriction of the use of reverse thrust;

The displacement of the point of touchdown;

The new landing systems implementations;

The use of a reduced number of operating engines during the taxiing aircraft;

The use of special vehicles for movement of aircraft from parking areas to runways;

Frankfurt airport pays for isolation from noise for the houses which are located near the airfield territory. The installation of triple glazing units decreases the noise for 40 DC. But even after that planes continue to destroy roofs of houses by turbulent flows which are moving with the speed of 150 km per hour. And airport again found a way out of this situation they have become hold elements of roofing brackets, clamps attached with reverse side to the bars and for wall tiles

and after that the tearing them become impossible. Between 23.00 and 5.00 they cancelled all flights .

#### 4 CONCLUSIONS

Many modern engines are already equipped with sound-absorbing cladding internal channels. They are perforated plates located at a short distance from the rigid wall. The space between the wall and the plates are filled with so called honeycomb as an isolation material. Another option for reducing noise power units is installation of special rods and nets.

It is proposed to create a soundproof enclosure around the jet blast, as well as to use a third-party noise source that extinguishes the main one. The use of a high degree of double-circuit on modern engines causes a significant decrease in the relative exhaust flow rate. It makes it possible to reduce the gradients of the flow velocity, and hence the noise of the free jet.

#### REFERENCES

- [1] <http://medical-diss.com/medicina/vozdeystvie-aviatsionnogo-shuma-na-zdorovie-naseleniya-v-usloviyah-kompleksnogo-tehnogennogo-zagryazneniya-sredy-obitaniy>
- [2] <http://avia.pro/blog/snizhenie-urovnya-shuma-ot-samolyotov-novye-tehnologii-ot-uchyonyh-iz-velikobritanii>
- [3] <https://aircargonews.ru/2017/11/23/yaponcy-nashli-sposob-snizheniya-shuma-sadyaschegosya-samoleta.html>
- [4] <http://www.dissercat.com/content/optimizatsiya-protsedur-ekspluatatsii-samoletov-grazhdanskoi-aviatsii-s-tselyu-umensheniya-i>

# 7 recommendations on how to quickly learn technical English

Tetiana Fediura

Department of telecommunication systems,  
Educational and Scientific Institute of Aeronavigation,  
Electronics and Telecommunications,  
National Aviation University  
Kyiv, Ukraine  
[tanyafediura@gmail.com](mailto:tanyafediura@gmail.com)

Anastasia Kobernik

Department of telecommunication systems,  
Educational and Scientific Institute of Aeronavigation,  
Electronics and Telecommunications,  
National Aviation University  
Kyiv, Ukraine  
[kobernika97@gmail.com](mailto:kobernika97@gmail.com)

**Abstract—** *A huge amount of information is available only in English. In particular, this problem is very important for technical specialists. Therefore, to learn English is necessary and very useful. In this paper, seven recommendations are given on how to quickly learn technical English.*

**Keywords—** *technical English, IT forums, English-speaking.*

## I. INTRODUCTION

English is spoken by more than 400 million people around the world and another 1.5 billion are using it as a second language. All programming documentation was originally written in English. Knowledge of English is a required condition for successful employment and career development of a programmer. According to statistics, more than 75% of orders for software development come to domestic specialists from foreigners and almost all customers prefer to communicate in English. That is why every IT-specialist must know it at a good level [1].

## II. FORMULATION OF THE PROBLEM

Not everyone has the opportunity to study English with a tutor. There is an opinion that beginners need to watch films and read books in the original language, in English. But a lot of words have different meanings depending on the context, because of this there are difficulties in understanding the text. We offer some practical advice on how to learn technical English quickly and efficiently.

## III. BASIC PART

### 1. Practicing every day

This is relevant for anyone who wants to learn a foreign language quickly. We suggest you don't look for excuses in established phrases such as "Rome wasn't built in a day." Whenever you've got a few minutes to spare, you can read the news in English, learn a few words, or watch a thematic video. Look for opportunities, not excuses. Download an audiobook in English to listen to while you are traveling on the metro, or a language-teaching application on which you can productively spend a few minutes.

### 2. Learning words by topic

For better memorization, we advise you study words in the context of their use. For example, in order to learn the

English terminology on the subject of telecommunications systems, familiarize yourself with thematic articles and select unknown words. After that, practise them, studying the materials on the topic, until you can do without a dictionary. This way of learning will allow you to understand the shades of meanings of words, which can not be achieved simply by memorizing a dictionary.

### 3. Reading English-language IT forums

Here you can find actual expressions that programmers around the world use for informal communication. It will be important for future communication with foreign colleagues and customers.

### 4. Following English-speaking programmers on social networks

Firstly, it is the source of new words and expressions. Secondly, you will be "in the subject" of the latest developments and new products from the world of IT.

### 5. Watching themed videos

Knowledge of vocabulary without experience of hearing it is not enough. In order to successfully communicate with foreign customers and colleagues, you must be able to understand the language by ear. In order to acquire this skill, we advise you to watch video from conferences, presentation.

### 6. Not forcing yourself to learn

We suggest you to find an interesting topic or news in English and try to translate it. When you realize that this will bring you results already now, for example, in the form of new knowledge about technologies, it is very motivating.

### 7. Practicing

We offer you to look for any opportunities to talk. Everyone knows this, but not many people take advantage of this essential rule. The absence of a language barrier, the ability to quickly switch to conversational mode and select the right words is one of the most important indicators of language proficiency at an advanced level. For example, you can chat with native speakers in text and video chats [2].

## REFERENCES

### IV. CONCLUSIONS

In this paper, seven basic recommendations are proposed to quickly study technical English. By following the recommendations, you can quickly and effectively learn English. The main thing is to regularly study, do not forget to practice. These tips will come in handy for technical professionals from different industries and will allow them to work with foreign colleagues and employers.

- [1] Electronic source: <http://englex.ru/english-for-it-specialists/>.
- [2] Electronic source: [https://geekbrains.ru/posts/english\\_10\\_tips/](https://geekbrains.ru/posts/english_10_tips/).



# Aviation and Environmental Protection

Horienkova Yu. M., Martsyniuk O. Ya.

Scientific Adviser Pershukova O. O.

Academic and Research Institute of Air-navigation, Electronics, and Telecommunications

National Aviation University

Kyiv, Ukraine

juliakubik94@gmail.com

**Abstract** — aviation causes a wide spectrum of factors of negative influence on the environment. In this connection the task of state normative acts development and introduction is timely and actual. These acts would regulate the location of settlements near-by airports as well as development of measures and recommendations in relation to the decline of negative influence of air processes on the an environment.

**Keywords** — aviation, ecology, noise pollution, contamination of locality, contamination of air, erosion of soil, contamination of reservoirs.

## 1 Introduction

Scientific and technical revolution brought the large blessing to humanity. One of major there is a possibility to be quickly moved to large distances. A man overmastered sky! But it is necessary to pay for everything.

When we hear a word "aviation", a picture appears: an airplane flies in the sky, on a high rate, overcoming large distances. How does he succeed to fly? How much harm is brought to the environment? We begin to think about these questions not at once.

## 2 Influence of air transport on ecosystems

The basic factors influencing the environment are:

1. Noise pollution localities;
2. Contamination of locality by the electromagnetic radiation;
3. Contamination of air by aero-engines;
4. Soil erosion of territories near the air field;
5. Contamination of reservoirs.

### 2.1 Noise pollution localities

The negative action of different aviation noise sources influences first of all on operators, engineers and technicians of productive subdivisions. Population of air city and located near-by settlements feel noise from airplanes that fly alongside.

Noise pollution of locality in civil aviation became a large problem with appearance of airplanes of large weight that are equipped by powerful engines. It is known that one ramjet of modern airplane is able to create noise intensity of 130 decibels, and at flight of airplane on forcing force of sound it can arrive 150 decibels. Harmful influence on the psyche of a

human being and his/her vegetative nervous system makes noise in 60 decibels.

Limit maximum of possible sound level on objects near the airfield is 112 decibels for daily time and 102 decibels at night. For this purpose, state standards for noise reduction have been developed and introduced.

The most effective means are to improve and create low noise engines. The noise reduction of airplanes is important not only in the interests of passengers, but also in the interests of civil aviation workers and residents.

### 2.2 Contamination of locality by the electromagnetic radiation

Except noise, the aviation carries out electromagnetic contamination of environment. This is caused by the radiolocation and radio navigation technique of airport and airplanes. Radiolocation facilities can create the electromagnetic fields of large tension that cause a threat for people [1].

At the constant action of hertz waves of small intensity there are disorders of the nervous and cardiovascular system, endocrine organs and others. A man feels irritation, headaches, weakening of memory and other. For the intensity of the harmful radiation reduction, it is also possible to increase the height of the setting to the radio locator or change the angle of the slope of the antenna.

### 2.3 Contamination of air by aero-engines

Extras from aero engines and stationary sources are the aspects of influence of air transport on the ecological situation.

Airships contaminate the ground layers of atmosphere and upper-air on the heights of cruiser flight. Exhaust gases of aviation engines make 87 percent of all extras of civil aviation. The most unfavorable are small speeds and "idling" of an engine. The technical state of the engine directly influences the ecological indexes of extras [2].

It is calculated, that proceeding in an ecological equilibrium is possible only for 10 percent of aviation contaminations, and 90 percent of them must be neutralized by realization of the special artificial nature protection measures.

In 2000 the absolute indexes of gross extras of harmful substances laid down 152000 tones. In Ukraine the volume of extras of harmful substances by airsoft civil aviation in the ground layer of atmosphere made 50000 tones, from them 29000 tones of carbon oxide, 11000 of hydrocarbons that did not burnout, 8000 of oxides of nitrogen and 2000 of sulphur oxides.

#### *2.4 Soil erosion of territories near the air field*

Soil erosion and contamination of territories near the airfield take place as a result of floods and waterproof soils. In some air fields due to negligent storage and fuel consumption, the concentration of petroleum products in water reaches 12 ml / l at the rate of 0.05 ml / l, i.e., exceeds 240 times. Plants perish on such soil, and to 30 percents of the harvest collected even from less muddy areas perish around.

#### *2.5 Contamination of reservoirs*

In civil aviation, the most intense sources of pollution of natural water are the equipment repairing and the special motor transport. The sewage water of air and air repair companies consists of productive and service communications and surface streams.

The amount of effluents and their composition changes during every twenty-four hours each week and month. A most danger for water objects is presented by flows from territory of airport. Superficial flows from territories of transport enterprises contain hydrocarbon oils, bits and pieces of washings, disinfectants, anti-freeze reagents, forming mixtures, solutions used in metal-boringness, exhaust electrolytes of storage batteries and wear of tires.

Atmospheric precipitation, rain streams and melted waters also take part in flue gases, harmful extras of cars and other civil aviation ling up of contaminants results in contamination of ecosystems and makes soils on adherent territories unsuitable for the agricultural use.

### 3 Conclusion

Harmful influence of aviation on the environment has global and local character. The influence of aviation on the ozone layer of atmosphere is global. At the local level the main problems are noise, contamination by extras and casts of harmful substances in atmospheric air, underwater and soil in the district of airports location.

For the ecological problems of civil aviation decision, it is necessary to work out:

1. Principles and methods of air defense from air ships engines contamination;
2. Principles and methods of protecting from the electromagnetic fields of radio frequencies;
3. Technologies of defense of soils and water from contamination of airports flow;

4. Schemes of air traffic control along the route and at airports optimization taking into account the state of the environment;

5. Methods of quantitative integral estimation of the ecological state of aviation transport enterprises. It is necessary to have at least two fundamental positions in the conception of formation and maintenance of commuter network:

1) During construction and operation of aero fields the nature should not be violated, and at their reconstruction there should be promoted the transition to a balance.

2) All the measures for the selection of areas, planning and construction of facilities should be carried out taking into account environmental requirements, working closely with the official authorities, local hydro meteorological and environmental organizations.

Outside the territory of the aerodrome, it is desirable to have a forest area of 100.140 kilometers of area. This makes possible to produce into the environment 70 000 tons of oxygen within one year and neutralize up to 1000 tons of poisonous gaseous substances which are emitted into the atmosphere.

#### References

- Kolotylo Dr M Ecology and ekonomika.- K., 1998  
Kolesnikov SI Ecological bases of nature raquo;. Textbook. Izdatel'stvo Dashkov and K raquo;, 2008  
Ecology, Health and /Pod.red of nature in Russia. Protasov VF - M., 1995. - 218 p.

# The use of idioms (phraseologisms) in aviation

Rigus Daniella Andriivna  
research advisor: Kolisnichenko Ganna  
department of foreign languages and applied linguistics  
National Aviation University  
Kiev, Ukraine  
daniella.guba@gmail.com

**Abstract- the work is devoted to the problem of using phraseology in aviation. The paper proposes constant expressions that can be used not only in scientific works, but also in the staff of airlines, as well as during training in a professional direction. The article is aimed at demonstrating the interaction of linguistic and additional linguistics aspects in idioms, as linguistic units, and a way of transforming linguistic aspects into additional linguistic and vice versa.**

## I. INTRODUCTION

The International Air Transport Association (IATA) conducted a study on phraseology in 2011. In the questionnaire for pilots including captains and first officers from around the globe, one of the survey questions was: "In what region do you most often experience an event where International Civil

Aviation Organisation (ICAO) standard phraseology is NOT used?" The results revealed that the North American region, with its 22%, had the highest number of events in which ICAO standard phraseology was not used. Similar results were found in the survey conducted among air traffic controllers (ATCs). The majority (52%) reported that they encounter situations where ICAO phraseology is not used on a daily basis, and further 25% said that those situations occur on a weekly basis. Controllers also had to specify the originating region of the airline pilots who deviate from standard ICAO phraseology, and the results showed that the majority of controllers chose Northern American pilots with 26%, followed by European pilots with 15%. The survey does not state in what form those deviations occurred, but it implies that Northern American pilots do not follow standard ICAO phraseology to the same extent as pilots from other regions of the world. My hypothesis is that American pilots, who are native English speakers, deviate from standard ICAO phraseology by using plain, conversational English, thus also deviating from the standard phraseology prescribed by Federal Aviation Association (FAA) that regulates aviation standards in the United States. In this research paper I focus on the communication between non-native English speaking air traffic controllers and native English speaking pilots on the example of an American airline aircrafts landing at an airport in Switzerland. ICAO has six official languages: Spanish, French, Arabic, Chinese, Russian, and English. Even though there is nothing in the language itself that made English more suitable than other languages to become the

foundation of the standard phraseology, the ICAO made a conscious decision after the Second World War to make it the international language of aviation when pilots and controllers speak different languages (Crystal 1997: 107), thus fulfilling the role of the 'lingua franca' of aviation. According to Jennifer Jenkins' book *World Englishes* (2009: 143), 'English as a Lingua Franca' (ELF) is used as a contact language among speakers from different first languages. However, English used in aviation is not a standard variety of the English language in Ukraine a sense that it has native speakers, but a 'phraseology' constructed for the specific purpose of air traffic communication, thus regarded as English for Special Purposes (Hyland 2002). Aviation English, and not plain English, is the lingua franca of aviation communication. This paper is about the thorny question of non-standard communication. I am well aware of the fact that in everyday working life of pilots and controllers, it is not unusual to deviate from the prescribed phraseology by using greetings such as good morning and hello. More specifically my research question is: in which form do deviations among native English speaking pilots occur in routine procedures where organizations responsible for international civil aviation strictly prescribe the usage of standard phraseology.

## II. NATURE OF RADIOTELEPHONY COMMUNICATION

Pilots and controllers communicate with each other through a radio. A certain radio frequency allows each of them to talk, and to hear what others said. On one frequency, one controller is talking to many pilots. In this paper I focused on the frequency where departures and arrivals are being controlled. Swiss laws make it obligatory that all participants speak English on all frequencies where Swiss controllers are navigating pilots. This ruling was implemented as it is considered safer if all pilots understand all conversations, that is all the information about positions of other aircrafts in the near proximity. Aircrafts are differentiated by their different names, which are in aviation called callsigns. A callsign is made out of letters denoting the name of the airline, and a number which marks the flight number of a certain aircraft. In order to make it clearer below is an example from chapter 5.2.1.9. Exchange of communication from the ICAO annex 10 on aeronautical telecommunication from 2001:

(a) Station (initiation):

TWA NINE SIX THREE MADRID — ATC  
CLEARS TWA NINE SIX THREE TO  
DESCEND TO NINE THOUSAND FEET  
Aircraft (readback):  
CLEARED TO DESCEND TO NINE  
THOUSAND FEET — TWA NINE SIX THREE

Pilots listen to the frequency at all times, and once the controller mentions their callsign, the communication is initiated. After the controller gives the instructions, the pilots need to repeat what they understood. This is called readback. Two most important reasons why standard phraseology is used is the nature of the radiotelephony communication, namely the poor sound quality of the radio and the fact that the frequency needs to be listened by all aircrafts in the same flight space. Standard phraseology is thus created to avoid communication failures such as ambiguities and misinterpretations. If those situations would occur in aviation, their consequences would be fatal.

### III. LANGUAGE FOR COMMUNICATION AND LANGUAGE FOR IDENTIFICATION

House (2003: 559) says that ELF “can be regarded as a language for communication, that is, a useful instrument for making oneself understood in international encounters.” And this is exactly what Aviation English is; it serves the purpose of a communication tool that aims to transmit the wanted message perfectly without any ambiguity, even if it does not have the same nature as plain English as a *lingua franca*. House (2003:559) makes a distinction between ‘languages for communication’ and ‘languages for identification’. Characteristics of a language for communication is not a national language, thus it is not a marker of identity, but a mere tool serving a communication purpose. And Aviation English truly is a language for communication, because it is not used outside of the aviation world. Thus it has no native speakers, and nobody is raised with the restricted phraseology of Aviation English as a mother tongue. Aviation English is truly a language used by an expert community of 14 aviation personnel, and its purpose is limited to the aviation setting. On the other side, House (2003:559) defines languages for communication as ‘national and local varieties for affective, identificatory purposes’. The difference between Aviation English and plain conversational English, is that Aviation English is a language for communication, whereas plain English is a language for identification. There is a functional distinction between these two varieties. Swiss non-native English speaking controllers use Aviation English in their work environment, but once their work is done, they speak their own mother tongue (French) which is their language for identification. But native English speaking pilots need to make this functional distinction, and use Aviation English at work and plain English outside of work, and as shown in examples (1a)- (7b) they find it hard to adhere to rules of Aviation English because their mother tongue, the language for

identification, keeps interfering with the prescribed phraseology.

### IV. CONCLUSION

This paper presents the nature of radiotelephony communication and discusses (Aviation) English as a *lingua franca*. Through the analysis of the collected data, this paper showed that native English speaking pilots deviate from the prescribed standard phraseology by resuming to plain English. What I did not take in account is the level of stress that pilots might have experienced, the length and complexity of message, the amount of workload, and all other components that could possibly be responsible for the natives resuming to plain language, thus deviating from standard phraseology. However, landings are an everyday work routine for every pilot, and standard phraseology must not only be followed during routine operations but is thought of as especially useful to make oneself clear and specific in emergency situations where the mental capacity might be overwhelming. It was beyond the scope of this study, but a further research question would be if there are differences among native English speakers, that is, if there are differences between native American and British or Australian speakers’ usage of standard phraseologies.

### REFERENCES

- [1]. Pliso A.-M. Non-Standard Phraseology in Aviation English-[ICAO and FAA Manuals].
- [2]. Heikki Reijonen (2005) General characteristic and origins of English idioms with a proper name constituent. University of Tampere Department of English.

# IT TECHNOLOGY FOR LEARNING THE ENGLISH LANGUAGE

Mariia Khomiuk

Student

National aviation university

Kiev, Ukraine

mariakhomiuk@gmail.com

**Abstract**—Technology is very much part of language learning throughout the world at all different levels. We are as likely to find it in the life as much as in adult education.

**Keywords**— *teaching, internet, technology, language, multimedia, video, apps, digital fields trips, podcasts.*

## 1 INTRODUCTION

Successful work in large companies always involves knowledge of a foreign language. Often the salary level of an employee is determined not only by the level of technical competence: for the opportunity to work in large international teams people need to communicate freely with colleagues and clients. In IT-technologies, knowledge of English is a standard that is necessary to follow.

Digital technologies are used for help teachers working with learners, and learners working independently, to do the necessary exercises that makes their language development possible.[5]

## 2 FORMULATION OF THE PROBLEM

There are a lot of ways to learn foreign languages. The biggest problem is to choose right way to use it correct and the most useful for our needs. Big amount of on-line programs and special technologies can disorient people to make right decision. [1]

## 3 WAYS TO USE TECHNOLOGIES

The key to success is the correct combination of the curriculum, the intensity of the training and the correct method of teaching.

Trying to find ways for people to do meaningful spoken language practice in a class can be very challenging, particularly if, as a teacher, you lack confidence in your own spoken language skills. Linking class to other classes around the world, using tools such as video conferencing, can give a reason for a learner to ask a question and then try to understand the response. The technology mediates the process, getting language out there and giving feedback that shows whether someone has or hasn't understood what person have said.

As the ways to use technology in learning English I can identify the most popular multimedia [2]:

- Film and video;

- Apps;
- Digital field trips;
- Podcasts;
- Pen pals;
- Web Quests;
- Blogging;
- Online games;
- Skype.

## 4 POSSIBILITIES OF STUDYING

The path to learning people can decide by themselves or with the help of ready-made programs that are in the public access on the Internet. Skype is the most popular way to learn languages with teachers. It's very comfortable to use this program for audio lessons and easy screen-share desktop to show PowerPoint presentations for learners. Also, exist special online resources which work with Skype automatically turning it when it needed.

We need to find something more sophisticated if we want to see results faster. Virtual platforms which combine few types of technologies created for this purposes. Self-study is obviously important in language learning. And such platforms give us a possibility to combine self-education and studying with teacher via Skype or other similar program.

There are such opportunities as free apps for learning languages on the go. [3] The most popular from this category are: British Council apps, Duolingo, Two min English. This give us access to manage out limited free time and make it more useful.

Online games become popular with each day. "Game to learn English" (created by powowbox) multi-level game is considered as a popular education way which combine fun with study. After downloading it appears as English tracker. Unfortunately, just first four levels are free, than, if learner like this app, he or she should buy it.

## 5 CONCLUSION

In this statement were offered popular multimedia technologies for language learning. To improve learning efficiency, it is recommended to combine these technologies or use sophisticated virtual platforms to improve the quality of the gained knowledge.

## REFERENCES

- 1 Crystal D. Language and the Internet / D. Crystal. – Cambridge: Cambridge University Press, 2004. – 272 p.
- 2 S. Guinan “Teaching English online: opportunities and pitfalls” - / <https://www.britishcouncil.org/voices-magazine/teaching-english-online-opportunities-pitfalls/>
- 3 E. Segev “Mobile learning: improve your English anytime, anywhere” - / <https://www.britishcouncil.org/voices-magazine/mobile-learning-improve-english-anytime-anywhere/>
- 4 Boyd “Use pop songs to learn connected speech and sound more fluent in English” - / <https://www.britishcouncil.org/voices-magazine/pop-songs-connected-speech-fluent-english/>
- 5 M. Sciamarelli “Should language teachers avoid global issues when teaching?” - / <https://www.britishcouncil.org/voices-magazine/should-language-teachers-avoid-global-issues-when-teaching/>

# Evolution of Avionics Systems

Vladyslav Kutepov

scientific adviser: Nataliia Zelinska  
Aviation English department,

Educational and Research Institute of Air Navigation, Electronics and Telecommunications,  
National Aviation University,

Kyiv, Ukraine

[vladcorvt@gmail.com](mailto:vladcorvt@gmail.com)

**Abstract**—This paper covers the evolution of aircraft avionics systems and its further development. It shows how avionics systems were developed from analogue to digital. The variant of future development of avionics systems is considered.

**Keywords**—*avionics; flight instruments; glass cockpit; ergonomics.*

## 1 INTRODUCTION

Avionics are the electronic systems used on aircraft, artificial satellites, and spacecraft. Avionic systems include communications, navigation, the display and management of multiple systems, and the hundreds of systems that fit to aircraft to perform individual functions. These can be as simple as a searchlight for a police helicopter or as complicated as the tactical system for an airborne early warning platform. The term “avionics” is a contraction of the words “aviation” and “electronics”. [1]

The term "avionics" appeared in the West in the early 1970s. By this time, electronic technology has reached such a level of development, when it became possible to use electronic devices in airborne systems, and thereby significantly improve the quality of aviation applications. At the same time, the first onboard electronic computers appeared, as well as essentially new automated and automatic control and monitoring systems.

Initially, the main customers of aviation electronics were the military. The logic of the development of military aviation quickly led to a situation where military aircraft can not only carry out combat missions without the use of electronic technical means, but even simply fly on the required modes of flight. Now the cost of avionics systems is a large part of the total cost of the aircraft. [3]

## 2 ERGONOMICS: A KEY FACTOR IN COCKPIT EVOLUTION

As the vital interface between an aircraft and its crew, the cockpit of a modern aircraft must provide – instantaneously and in a convenient manner – all the information the crew needs to assess the aircraft’s status and take appropriate action, regardless of the circumstances. As a result, the cockpit is a key arena for improvements in human-machine interface (HMI) technology. The HMI that enables the pilot to use his senses, brain and movements to control an extraordinarily

complex machine in an environment to which human beings are not naturally accustomed.

Cockpit ergonomics naturally make a key contribution to crew comfort and performance. The Society for Automotive Engineers (SAE) issues Aerospace Recommended Practices (ARPs) for cockpit design, layout, installation and operation, which contain minimum requirements for the pilot’s position in relation to the following aspects:

- the ability to reach the controls without effort from a reference position (seatbelt attached, shoulder harness unlocked, pilot’s eyes in reference position);
- visibility of flight instruments without undue effort;
- minimum visibility outside the cockpit;
- easy oral communication inside the cockpit.

The accessibility of the primary flight controls is, naturally, very important.

## 3. THE SHIFT FROM ANALOGUE TO DIGITAL

Until the 1970s, the walls of civil airliner cockpits – in fact every surface that was within the pilots’ reach – were studded with indicators, instruments and electromechanical controls. The controls, with their arrays of complicated dials, were generally designed for a three-man crew: two pilots and an engineer. A typical trans-port aircraft from this period had more than 100 instruments and controls, the most important of which were packed with bars, needles and symbols. All of these displays jostled for space on the various instrument panels, and competed for the pilot’s attention. Research aimed at finding a solution to this problem, conducted in particular by NASA in the United States, led to the development of display devices capable of processing flight data, and the raw information provided by aircraft systems, and integrating it into an easily understandable synthetic image.

This development was only possible because of a fundamental change in the type of information processed by onboard systems. Earlier instruments, based on analogue information, provided indications that were directly linked to the associated physical phenomena (for example air pressure, airspeed, or the position of a gyroscope). Digital information, on the other hand, results from the conversion of a physical measurement into binary code by means of an analogue-digital converter.

The digitization of the physical data required for flight control and navigation, as well as for more general operational and informational purposes, led to a profound change in aircraft cockpits from the 1970s onwards. Thanks to improvements in electronics and computer technology, data could now be converted from analogue to digital format, processed by computers, and displayed on computer-type screens in the cockpit.

#### 4. THE REVOLUTION OF THE “GLASS COCKPIT”

In fact, this profound change in the appearance and layout of cockpits was driven by two key technical improvements: the availability of sufficiently capable and reliable electronic systems for digitizing and processing information; and the development of cathode-ray tubes (CRTs), like those used in computer monitors, but capable of adapting to the extremely variable ambient light conditions in aircraft cockpits.

These two innovations led to the replacement of the main electromechanical flight instruments with computer-type displays, and consequently to a change in the way information on the status of onboard systems and alarm signals were presented. The combination of these technological developments led to the emergence of the first generation of what are now dubbed “glass cockpits”. In the early 1980s, this new cockpit concept was adopted for the Airbus A310 and the Boeing 757 and 767. Combined with other innovations such as the flight management system (FMS), the introduction of the glass cockpit made it possible for these large aircraft to be flown by a flight crew of two. The A310 was equipped with an electronic flight instrument system (EFIS) comprising six shadow mask<sup>1</sup> color CRT screens, three computers, and associated control stations providing the pilot and co-pilot with essential flight control and navigation information, as well as synthetic data on the status of aircraft systems and alarms. The human-machine interface was thus significantly improved, with new functionalities becoming available, such as display of simple graphic charts and simplified diagrams of onboard systems. Each screen had a useful area of 5 x 5 inches (12.5 x 12.5 cm), which seems small today, but was nothing short of a revolution at the time. With this new technology, the instrument panel of the A310 could be significantly simpler than the analogue cockpits of previous generations of aircraft (although the engine data indicators in the central area continued to use electromechanical technology).

#### 5. TOWARDS THE FUTURE OF AVIATION AND FLIGHT

The 21st century takes hold of the cockpit. LCD technology becomes the norm, generating weight savings and multiplying display capacity. Touchscreen technologies also enter the cockpit, providing the pilot with new ways of interacting with the aircraft system. These new capabilities have huge potential for the future. We are now able to integrate the means of interaction which, through smartphones, have become a part of our everyday lives, thus increasing the capacity and user-friendliness of future cockpits. [2]

#### 6. CONCLUSIONS

In this article, the history of development of avionics systems was described. We saw how avionics systems has evolved from analogue to digital. Various options of avionics systems were considered as such types of avionics systems as original, classical, glass cockpit. The options of avionics systems development were proposed.

#### REFERENCES

- [1] <https://en.wikipedia.org/wiki/Avionics>
- [2] <https://www.thalesgroup.com/en/global/activities/aerospace/flight-deck-avionics-equipment-functions/flight-deck/learn-more-about>
- [3] <https://ru.wikipedia.org/wiki/Авионика>



# Problems of aviation communication using language proficiency standards

Leonchuk Y., Yerina T.  
Supervisor: Pershukova O. O.  
ESIAET, NAU  
Kyiv, Ukraine  
[leo.yulia.iam@ukr.net](mailto:leo.yulia.iam@ukr.net)  
[Erina@ukr.net](mailto:Erina@ukr.net)

*This study explores the potential impact of 'non-native English' in pilot-air traffic control transmission. Results support that communication errors, defined by incidents of pilots misunderstanding, occur significantly more often when speakers are both non-native English, messages are more complex and when numerical information is involved.*

**Keywords – aviation english, communication errors, language proficiency standards, dialect difficulties.**

Although English has been the international aviation language since 1951, formal language proficiency testing for key aviation personnel has only recently been implemented by the International Civil Aviation Organization (ICAO). It aims to ensure minimum acceptable levels of English pronunciation and comprehension universally, but does not attend to particular regional dialect difficulties. However, evidence suggests that voice transmissions between air traffic controllers and pilots are a particular problem in international airspace and that pilots may not understand messages due to the influence of different accents when using English.

There are three ways that can be a contributing factor language in accidents and incidents:

- a) incorrect use of standardized phraseologies;
- b) lack of plain language proficiency;
- c) the use of more than one language in the same airspace.

These results and their possible implications are discussed with reference to the development of ICAO's new language proficiency standards. A pyramid structure of ICAO's language proficiency skills looks like that:

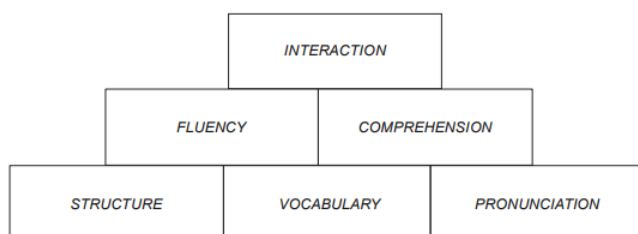

This study builds on previous work and literature, providing further evidence to show that the risks caused by language and linguistics in aviation must be explored more deeply. Findings are particularly contemporary and relevant today, indicating that recently implemented international standards would benefit from further exploratory research and development. Problems of communication have been found to be an important or even the decisive causal factor for many critical incidents as well as near and actual accidents in aviation (see, among others, Cushing, 1994; Helmreich & Merritt, 1998; Isaac, 1999; Jones, 2003; Krifka, Martens &

Schwarz, 2003; Maschke, 1994; Silberstein & Dietrich, 2003: 10; Tajima, 2004; Turner & Nübold, 1981). This holds for both the communication among members of the crew in the cockpit and the communication between pilots and air traffic controllers. Among the languages used as the means of communication in aviation, English plays the dominant role. A substantial share of flights are and have been set within a national context where English is the official language; English serves most often as a lingua franca among the members of an international cockpit crew; a semi-artificial sublanguage based on English serves as the standard means of verbal communication between pilots and air traffic controllers both in English-speaking countries and where international airports are involved. This suggests a significant relevance of the linguistic study of English as well as of communication conducted in English for safety issues in aviation. Surprisingly, however, there has been comparatively little work done by linguists – in the sense that includes linguistic pragmatists – or in collaboration with linguists in this area.

So the main points that should be used:

- 1) rules about the order of priority between different types of messages;
- 2) a spelling code for letters and numbers;
- 3) rules for the expressions of call signs (by which aircraft and ground stations are identified);
- 4) rules about the message structure;
- 5) rules about which messages to send in cases of emergency;
- 6) a list of conventional expressions and their meanings;
- 7) a set of skeleton messages, i. e. a phraseology.

A conducting research on communication in aviation from the point of view of a linguist certainly contributes to a deeper understanding of the issues involved. Finally, the investigation of language in the context of aviation, where very much depends on communicative success, may make the linguist and the communicative practitioner most sharply aware of and sensitive to the processes and problems involved in linguistic behavior in any field of social interaction.

## REFERENCES

1. Advanced Aviation Modelling. John Mcillmurray
  2. Aviation English book for ICAO compliance. Henry Emery and Andy Roberts
- English for Aviation/ for Pilots and Air Traffic Controllers. Sue Ellis and Terence Geright

# Brain as an Ultimate Security Password

Oleksandr Linnyk

scientific advisor: Nataliia Zelinska

Aviation English department,

Educational and Research Institute of Air Navigation, Electronics and Telecommunications,

National Aviation University,

Kyiv, Ukraine

[alexlin@i.ua](mailto:alexlin@i.ua)

**Abstract**—The paper is dedicated to the personal data security methods. In order to make identifying people more secure a conception of the brainprinting which allows us to use the brain as a unique password and identify the owners was introduced. As a result, a reliable protection of our vulnerable information can be received.

**Keywords**—brain; brainprint; password; functional magnetic resonance imaging; electroencephalography; fingerprinting; security; identification.

## 1 INTRODUCTION

Biometrics is a process of measurement and statistical analysis of people's unique physical and behavioural characteristics. The technology is mainly used for identification and access control, or for identifying individuals who are under surveillance. The basic premise of biometric authentication is that every person can be identified by his intrinsic physical or behavioural features [1].

However, this is not proof either – it is possible to copy such biometrics features of people. Fingers can after all be chopped off and placed by impostors to gain fraudulent access. It has also been shown that prints taken from glass or other solid substances can be used with gelatine to create fake prints. So there is a real need to come up with more advanced biometrics that are difficult or impossible to forge. Moreover, a good alternative is the brain.

## 2 A PROBLEM TASK

Emerging biometric technology based on the electrical activity of our brain have indeed shown potential to be fraud resistant. Over the years, a number of research studies have found that “brainprintings” (that are the readings of how the brain response to certain actions or tasks) are unique for individuals as each person’s brain thinks differently. In fact, the brain can be used to identify someone from a pool of hundred users with more than 98% accuracy now, which is very close to that of fingerprints (99.8% accuracy).

More recently, this has been confirmed by functional magnetic resonance imaging (fMRI), which measures brain activity by tracking changes in human blood flow. A study using fMRI data from the Human Connectome Project was able to recognise individuals with up to 99% accuracy when performing certain mental tasks such as relaxing, listening to a music, solving complex problems, looking at emotional faces or moving parts of humans body.

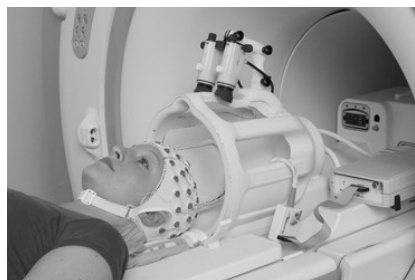

Fig. 1, fMRI procedure [4]

However, the cost and difficulty of using fMRI means that it is not profitable and suitable for everyday biometric authentication. For that reason, researchers have instead looked at electroencephalography (EEG). Electroencephalography (EEG) is an electrophysiological monitoring method to record electrical activity of the brain. [5] But this is also fool – who would be willing to wear a cap of gel-based electrodes just to log in to their computer? Hence, the technology has remained in the realm of science fiction for some time.

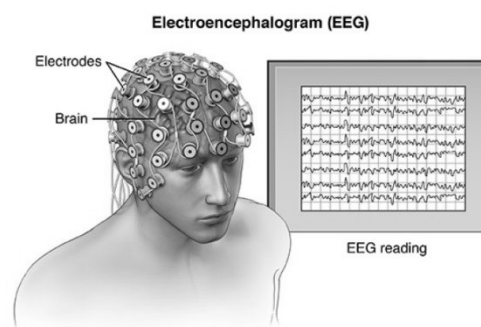

Fig. 2, EEG procedure [3]

“In “Brainprint,” a newly published study in academic journal *Neurocomputing*, researchers from Binghamton University observed the brain signals of 45 volunteers as they read a list of 75 acronyms, such as FBI and DVD. They recorded the brain’s reaction to each group of letters, focusing on the part of the brain associated with reading and recognizing words, and found that participants’ brains reacted differently to each acronym, enough that a computer system was able to identify each volunteer with 94 percent accuracy. The results suggest that brainwaves could be used by security systems to verify a person’s identity.” [6]

Recently, technological advances in recording EEG from the ear using electrodes placed on the surface of standard earphones have provided a solution – we don't need gel. It is not easy though – EEG is very “noisy” since the brain is always actively processing different information. But advanced signal-processing approaches have recently been able to reduce the noisy components, albeit this typically requires powerful computing. This is, however, becoming less of a problem now that mobile-phone processing power is growing rapidly – it should in theory be possible to perform all the required processing on a smart phone.

So why haven't we already used brainprints? The only disadvantage is that it can't be used by twins – they have near-identical EEG patterns. But the main problem is the lack of stability of brainprints over time.

It seems that it is not enough to just have an EEG done once – because it's necessary to do it every month. This is because the brain connections exhibit plastic behaviour (they change with experience) and thought processes in the brain change over time. However, in ongoing work at the University of Kent, we have shown that specific tones can be used to minimise these changes. It is not yet clear exactly how these tones affect the brain but we speculate that they may allow the brain to calm down, allowing more focused activity.

Two-factor authentication is now a norm for many banking transactions, for example using a password and an additional code sent to the phone. Soon, banks in New York may have to comply with multi-factor authentication protocol proposed by the New York State Department of Financial Services, whereby at least three authentication mechanisms are used for enhanced security by personnel accessing internal systems with privileged access or to support functions including remote access.

While fingerprints and voice recognition are possibilities, thought-based biometric technology is more apt to be used as an add-on to meet this new cybersecurity regulation. The brain biometric template could even be updated for a different mental activity should there be a security breach on the stored template (unlike a fingerprint biometric which remains for life and cannot be replaced once compromised) [2].



Fig. 3, Brainprinting user

Brainprints can also be used to generate passwords that can replace conventional alphanumeric passwords or PINs in ATM machines to withdraw cash. For example, rather than entering the PIN, one would connect earphones. Brain patterns would change when the correct PIN number showed up – activating the transaction. By doing so, one does not have to worry about others looking over the shoulder to steal the PIN. Moreover, brainprints will not work due to the stress – making them even more fraud resistant.

After all, both cognitive fingerprints and brainprints offer the promise of continuous authentication, which is a marked improvement over the periodic authentication provided by logging on using a password or an iris [7].

### CONCLUSIONS

Our brain is a unique part of our body, and it can be used not only as we use it now, but it also can serve as identification part for each person in the world. Through this, we could easily use it instead of fingerprints and eyes scanning and it would give as a more secure and reliability.

Taking into account all the above mentioned, it is difficult to copy another person's exact thought process; the technology is certainly advantageous. Considering the advancement in the technology, we will likely see uptake of biometric applications based on brainprints soon – especially as part of multi-factor system for enhanced authentication. So don't be surprised to see EEG earphones appearing in your post from the bank shortly.

### REFERENCES

- [1].<http://searchsecurity.techtarget.com/definition/biometric>
- [2].<https://theconversation.com/your-brain-is-unique-heres-how-it-could-be-used-as-the-ultimate-security-password-74311>
- [3].<http://www.brightbraincentre.co.uk/electroencephalogram-eeg-brainwaves/>
- [4].  
<http://www.uib.no/en/rg/fmri/108133/methodology>
- [5].  
<https://en.wikipedia.org/wiki/Electroencephalography>
- [6].<https://techcrunch.com/2015/06/04/your-brain-waves-could-replace-passwords/>
- [7].<https://nakedsecurity.sophos.com/2015/05/21/how-your-next-password-could-be-your-brain/>

# Aviation English: language of International Civil Aviation

Malimon O.Y.

Academic and Research Institute of Air-navigation, Electronics, and Telecommunications  
National Aviation University  
Kyiv, Ukraine  
malimonsasha9@gmail.com

**Abstract** — Flight safety depends on the effective propagation and transformation of linguistic representations both among and within operators. The use of multiple languages and especially languages that are not fully mastered may therefore affect the safety and efficiency of flight operations.

**Keywords** — Aviation English; civil aviation; ICAO; air traffic control; aviation phraseology; native speakers; Accidents.

## INTRODUCTION

The International Civil Aviation Organisation (ICAO) has introduced language proficiency requirements for air traffic controllers and pilots with the objective to improve the level of language proficiency globally and reduce the frequency of communication errors. Historically, insufficient English language proficiency on the part of the flight crew or the controller has contributed to a number of accidents and serious incidents.

The ICAO Language Proficiency requirements are applicable to both native and non - native English speakers. According to ICAO the burden for improved communications should not be seen as falling solely on non-native speakers - ICAO Doc 9835 states: “Native speakers of English, too, have a fundamentally important role to play in the international efforts to increase communication safety.” [1]

## INTERNATIONAL AVIATION LANGUAGE

English has been chosen as the official language of flight in the United States and continues to be the recommended lingua franca for international use. In some cases, a lack of English proficiency in pilots or controllers has led to disastrous and even fatal catastrophes. While miscommunications between flight crews and air traffic control (ATC) personnel may have been only one aspect of these incidents and accidents, the lack of ability for all parties involved to understand crucial directions via a common English may have been the most important contributing factor leading to these tragedies. Without agreed upon standards for English proficiency and common phraseology, the aviation industry continues to be at risk for future language-related accidents. Air traffic communications often deviate from standard phraseology in emergency situations towards a more conversational style. [2]

English proficiency beyond the basic understanding of aviation phraseology may be necessary. In addition, a cultural awareness of the variety of English spoken in countries encountered during flight may help avoid misunderstandings and miscommunications.

## ACCIDENTS AND INCIDENTS

- Vehicle / PAY4, Perth Western Australia, 2012 (Whilst a light aircraft was lined up for departure, a vehicle made an incorrect assumption about the nature of an ambiguously-phrased ATC TWR instruction and proceeded to enter the same runway. There was no actual risk of conflict since, although LVP were still in force after earlier fog, the TWR controller was able to see the vehicle incursion and therefore withhold the imminent take off clearance. The subsequent Investigation noted that it was imperative that clearance read backs about which there is doubt are not made speculatively in the expectation that they will elicit confirmation or correction.)
- CRJ2, en-route, Jefferson City USA, 2004 (On October 14, 2004, a Bombardier CRJ-200 being operated by Pinnacle Airlines on a non revenue positioning flight crashed into a residential area in the vicinity of Jefferson City Memorial Airport, Missouri after the flight crew attempted to fly the aircraft beyond its performance limits and a high altitude stall, to which their response was inappropriate, then followed.)
- B735, vicinity London Heathrow UK, 2007 (On 7 June 2007, a Boeing 737-500 operated by LOT Polish Airlines, after daylight takeoff from London Heathrow Airport lost most of the information displayed on Electronic Flight Instrument System (EFIS). The information in both Electronic Attitude Director Indicator (EADI) and Electronic Horizontal Situation Indicators (EHSI) disappeared because the flight crew inadvertently mismanaged the Flight Management System (FMS). Subsequently the crew had difficulties both in maintaining the aircraft control manually using the mechanical standby instruments and communicating adequately with ATC due to insufficient language proficiency. Although an emergency situation was not declared, the ATC realized the seriousness of the circumstances and provided discrete

frequency and a safe return after 27 minutes of flight was achieved.)

- SH33 / MD83, Paris CDG France, 2000 (On the 25th of May, 2000 a UK-operated Shorts SD330 waiting for take-off at Paris CDG in normal visibility at night on a taxiway angled in the take-off direction due to its primary function as an exit for opposite direction landings was given a conditional line up clearance by a controller who had erroneously assumed without checking that it was at the runway threshold. After an aircraft which had just landed had passed, the SD330 began to line up unaware that an MD83 had just been cleared in French to take off from the full length and a collision occurred.) [3]

#### CONCLUSIONS

The current stage of the development of communication systems of aircraft is characterized by scientific and technological progress, which respectively leads to an increase in safety requirements.

ICAO requires that language skills of pilots and controllers rated at Level 4 are reassessed every four years, Level 5 every six years, while at Level 6 no further assessment of English

language skills is considered necessary. The level 4 (operational) skill is considered as a minimum 'stepping stone' to higher levels.

The main advantage of high international standards of aviation is that communication between aircraft crew and controllers is fully understood, especially when using non-standard words and phrases.

Also, improved language skills could help to increase the situational awareness of flight crews in relation to other aircraft both in the air and on the ground.

#### REFERENCES

- G. Daniel Morrow, Michelle Rodvold, Mark K. Smolensky, Earl S. Stein, "Communications issues in Air Traffic Control" in Human factors in Air Traffic Control, San Diego, CA:Academic Press, pp. 421-456, 1998.]. <https://www.icao.int/SAM/Documents/2003/RAAC8/RAAC8IP18.pdf>
- David Crystal, "Why English? The cultural legacy" in English as a global language, Cambridge, UK:Cambridge University Press, pp. 78-112, 1997.
- Joan M. Feldman, "Speaking with one voice", Air Transport World, vol. 35, no. 11, pp. 42-51, 1998.

# The Usage of Abbreviations and Codes in Aviation English

Malyshkin O.V.

Pershukova O. O. – professor

Academic and Research Institute of Air-navigation, Electronics, and Telecommunications

National Aviation University

Kyiv, Ukraine

Oleg290196@i.ua

**Abstract** — Nowadays airplane is the claimed type of transport. Accordingly, aviation industry develops swiftly. Safety of flights is the most important factor. But sometimes inability of pilot to report about a disrepair aboard an airplane results in a catastrophe. On it safety of flight of airplane depends on of communication skills of pilot and his knowledge of terminology.

**Keywords** — Aviation English; abbreviation; acronym; communication skills; professional language; terms.

## 1 INTRODUCTION

Aviation English is the international language of civil aviation. With the expansion of air travel in the 20th century, there were safety concerns about the ability of pilots and air traffic controllers to communicate. In 1951, the International Civil Aviation Organization (ICAO) recommended in "ICAO Annex 10 ICAO to the International Chicago Convention" that English be universally used for "international aeronautical radiotelephony communications". Despite being a recommendation only, ICAO aviation English was widely accepted.

English became language of international flying in the years after World War II, as commercial aviation expanded worldwide. Since then ICAO releases language proficiency requirements resulting in higher English-language standards. Some of the standards which concern abbreviations, acronyms and codes are expounded in "ICAO Abbreviations and Codes".[1]

## 2 SPECIFIC OF AVIATION ENGLISH

### a. Language Proficiency Requirements

The ICAO has introduced the language proficiency requirements for air traffic controllers and pilots with the objective to improve the level of language proficiency globally and reduce the frequency of communication errors.

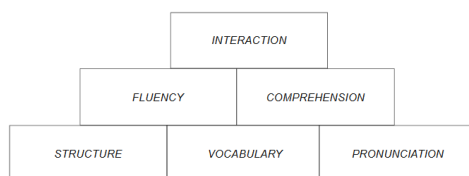

Fig. 1. A pyramid structure of language proficiency skills

Linguistic proficiency in listening and speaking can be broken down into component skills (Fig. 1). The six skills are:

- Pronunciation;
- Structure;
- Vocabulary;
- Fluency;
- Comprehension;
- Interactions.

Pilots and controllers working in international civil aviation must demonstrate proficiency to a minimum Operational Level 4. Level 4 is defined as the level of English, where vocabulary and grammar are good, but also where "pronunciation, stress, rhythm and intonation" are adequate to communicate clearly and quickly in professional situations. [2]

### b. Professional terminology

Professional terminology is an important part of any languages. And English is not an exception. Aviation English has many specific words, terms, abbreviations, acronyms and codes. So, proper translation of professional terminology is the basis of professional aviation documents and correct communication. Also, It is an important means of intercultural communication in aviation environment.

Concordantly to the lecture of the Intergovernmental aviation committee, appearance of airlines of countries of the CIS on international air-routes resulted in the considerable increase of aviation events and catastrophes for lack of domain English. One of principal reasons of aviation catastrophes is low level of English of knowledge.

## 3 ABBREVIATIONS AND CODES IN AVIATION ENGLISH

### a. Role of abbreviations in languages.

#### Principles for formulation of abbreviations

An abbreviation (from Latin *brevis*, meaning short) is a shortened form of a word or phrase. It consists of a group of letters taken from the word or phrase. The usage of abbreviations helps make communication of information faster and clearer. And an aviation industry isn't an exception. Usually abbreviations appear from the first letters of words, for

example: *ICAO – International Civil Aviation Organization, LVP – low visibility procedures, PFD – primary flight display.*

According to "ICAO Abbreviations and Codes" the principles applied in the formulation of ICAO abbreviations are:

- that allocation of more than one signification to a single abbreviation should be avoided except where it can be reasonably determined that no instances of misinterpretation would arise;
- that allocation of more than one abbreviation to the same signification should be avoided even though a different use is prescribed;
- that abbreviations should make use of the root word or words and should be derived from words common to the working languages except that where it is impracticable to apply this principle to best advantage, the abbreviation should follow the English text;
- that the use of a singular or plural form for the signification of an abbreviation should be selected on the basis of the more common use.[3]

*b. Types of aviation English abbreviations*

There are four different types of abbreviations in English:

- Acronym
- Initialism
- Shortening
- Contraction

Acronyms are a type of abbreviation that is pronounced as a word. They are formed by using the first letters in the words of a phrase or first parts of a phrase. For example: *SPI – Special position indicator, OSV – Ocean station vessel, MOA – Military operating area, EAT – Expected approach time, CRM – Collision risk model.*

Initialisms are a type of abbreviation where you pronounce it by saying each letter one at a time. Many of the abbreviations used in text messaging are initialisms. They are formed by using some of the letters in the word or phrase. For example: *ABM – Abeam, GRVL – Gravel, MSG – Message.*

A shortening is an abbreviation in which the beginning or end of the word has been omitted. For example: *JUN June, MAX Maximum.*

Contractions are abbreviations in which we omit letters from the middle of a word. The first letter is a capital letter only if the full word starts with a capital letter. For example: *AS – Alstratus, WT – Weight, YR – Your.*[4]

#### 4 CONCLUSIONS

Safety of flights is the most important factor. But sometimes inability of pilot to report about a disrepair aboard an airplane results in a catastrophe. On it safety of flight of airplane depends on of communication skills of pilot and his knowledge of terminology.

Aviation English is the international language of civil aviation. The set of six language proficiency skills set out in

ICAO with which all pilots and controllers working in international civil aviation must comply. Pilots and controllers working in international civil aviation must demonstrate proficiency to a minimum Operational Level 4.

An abbreviation is a shortened form of a word or phrase. It consists of a group of letters taken from the word or phrase. The usage of abbreviations helps make communication of information faster and clearer. So, it will help to protect human lives.

#### REFERENCES

- Status of English Language Standard for Use in Civil Aviation [Electronic resource].  
<https://www.icao.int/SAM/Documents/2003/RAAC8/RAAC8IP18.pdf>
- Manual on the Implementation of ICAO Language Proficiency Requirements Doc 9835. — Eighth Edition. — ICAO, 2010. — 150 p.
- Procedures for Air Navigation Services. ICAO abbreviations and codes: ICAO Doc 8400. — Eighth Edition. — ICAO, 2010. — 109 p.
- Types of English abbreviations [Electronic resource].  
<https://www.crownacademyenglish.com/types-english-abbreviations>

# Working memory of an ATC and its influence on Air Traffic Service

Mohyla Andrii, student

Supervisor: Pershukova O. O.

Scientific and Research Institute of Air Navigation, Electronics and Telecommunications

National Aviation University

Kyiv, Ukraine

[mogila.an11@gmail.com](mailto:mogila.an11@gmail.com)

**Abstract** – Air traffic controllers are the key pillars in the process of Air traffic service provision and their mental and psychological capabilities define the capacity of airspace sectors. Discussed possible ways to improve and enhance the working memory of an Air traffic controller thus increasing the capacity of airspace.

**Keywords**—*working memory; airspace capacity; human operator; mental capability.*

## I. INTRODUCTION

Demand for the aviation industry transport is continuously growing and the number of passengers will double in the next 15 years [1] which causes airspace capacity shortage. With the recent rates of technological advancement we can expect significant increase in efficiency of Air traffic service (ATS) and the only remaining drawback in the system is a human operator, as a central component of decision making. The Air traffic controller (ATC) needs to memorize constantly a significant amount of heterogeneous information and be able to operate it in a real time without the use of auxiliary sources. Such information may include aircraft callsigns, coordination points, courses and speeds of aircraft, meteorological data and information from the pilots. At high rates of signal processing, a large mental workload falls on working memory of an ATC. [2]

## II. WORKING MEMORY OF AIR TRAFFIC CONTROLLER IN DECISION MAKING

Air traffic service system capacity according to ATC Capacity Analyzer (CAPAN) method developed by Eurocontrol is defined by a combination of: airspace geometry, basic traffic data, flight parameters (conflicts, procedures, separation minima) and ATC task performance. [3] Another method, described by Arnab Majumdar and Washington Y. Ochieng from Centre for Transport Studies Dept. of Civil & Environmental Engineering, Imperial College of London. This method defines sector capacity “as the maximum number of aircraft controlled in a sector per hour given this threshold controller loading” [4]. Definitely, every method estimating the capacity of airspace sector is based on ATC’s performance under set level of workload. The workload of an average ATCO can be measured in different ways and approaches (Physiological metrics, Operator-subjective metrics, Performance metrics), but decision making process always plays a crucial role [5].

Dougherty and Hunter proved in their experiment that working memory span has an impact on the number of alternatives that a person can compare when making a decision, which means that people with a higher span of working memory will be able to analyze more options while taking a decision [6]. Moreover, Salthouse in his experiment proved that higher working memory span does not imply longer time for processing of information and thus decision making, but vice versa [7]. Tversky and Kahneman also assert that a person with a higher working memory capacity would be less likely to fall for the conjunction fallacy (multiple specific conditions are more probable than a single general one) or in aviation terms, expectations bias [8]. It is obvious, that working memory and its capacity will always remain one of the determinative factors in decision making process and affecting the capacity of airspace in general.

## III. POSSIBLE SOLUTIONS AND IMPROVEMENTS

Strict selection process always worked as a solution for choosing only those candidates, whose mental and psychological capabilities fit for the intense working environment in Air traffic control. First European Air Traffic Control Test selection rate is only 6% [9]. Another option for increasing the capacity of airspace and enhancing the decision making process of ATC would be usage of personalized working equipment and decreasing of time spent on voice communication. FAA conducted extensive research, showing that about 29% of the session in low workload conditions, controller spent speaking. Eliminating this time and moving all the routine communicating to Data channels with visual information representation will significantly reduce the workload, load on working memory and enhance a decision making process [10]. Also, one of the solutions would be transferring all the routine and standardized air traffic scenarios to Artificial intelligence platform, which will be sending all the commands via data sharing channel directly to the pilots or pilotless aircraft [11]. That way, ATC’s duties will be only oversight of system’s work, solving conflict situations and decision making in non-standard situations.

## IV. CONCLUSIONS

Summarizing, it is obvious that working memory of an ATC plays crucial role in the process of decision making.



Air traffic service providers all around the world use selection process to find the best candidates, trying to reduce the workload from radio communication and start implementing advanced automation to assist controllers.

## REFERENCES

- IATA Forecasts Passenger Demand to Double Over 20 Years, IATA Press Release No.: 59, 18 October 2016
- [2] P. Averty, S. Athenes, C. Collet and A. Dittmar, "Evaluating a new index of mental workload in real ATC situation using psychophysiological measures," *Proceedings. The 21st Digital Avionics Systems Conference*, 2002, pp. 7A4-1-7A4-13 vol.2.
- [3] Ruffaale Russo "CAPAN Methodology Sector Capacity Assessment" Air Traffic Services System Capacity Seminar/Workshop Nairobi, Kenya, 8 – 10 June 2016
- [4] Arnab Majumdar, Washington Y. Ochieng, Gerard McAuley, Jean Michel Lenzi and CatalinLepadatu "The factors affecting airspace capacity in Europe: A Framework Methodology based on Cross Sectional Time-Series Analysis using Simulated Controller Workload Data" Centre for Transport Studies Dept. of Civil & Environmental Engineering, Imperial College London, EUROCONTROL DAS/AFN Division, Brussels, Belgium
- [5] Peter Brooker "Control workload, airspace capacity and future systems" Human Factors and Aerospace Safety 3(1), Ashgate Publishing, 2003
- [6] Michael R. P. Dougherty and Jennifer hunter "Probability judgment and subadditivity: The role of working memory capacity and constraining retrieval", University of Maryland, College Park, Maryland, 2003
- [7] Timothy A. Salthouse "Theoretical Perspectives on Cognitive Aging", School of Psychology, Georgia institute of Technology, Atlanta, GA
- [8] Daniel Kahneman "Maps of Bounded Rationality: Psychology for Behavioral Economics", the American Economic Review, 93(5), pp. 1449-1475, December 2003
- [9] Eurocontrol, <https://atco.eurocontrol.int/> 2017
- [10] Carol A. Manning, Scott H. Mills, Cynthia M. Fox, Elaine M. Pfeleiderer, Henry J. Mogilka "Using Air Traffic Control Taskload Measures and Communication Events to Predict Subjective Workload" Office of Aerospace Medicine Washington, DC 20591, DOT/FAA/AM-02/4
- [11] Geoffrey D. Gosling "Identification of artificial intelligence applications in air traffic control", Transportation Research Part Volume 21, Issue 1, January 1987, Pages 27-38

# Bird strike

Volodymyr Opareniuk

scientific adviser: Nataliia Zelinska  
Aviation English department,  
Educational and Research Institute of Air Navigation,  
Electronics and Telecommunications,  
National Aviation University,  
Kyiv, Ukraine  
[opareniukvova@gmail.com](mailto:opareniukvova@gmail.com)

Vladyslav Schugailo

scientific adviser: Nataliia Zelinska  
Aviation English department,  
Educational and Research Institute of Air Navigation,  
Electronics and Telecommunications,  
National Aviation University,  
Kyiv, Ukraine  
[vlad.shugailo@ukr.net](mailto:vlad.shugailo@ukr.net)

**Abstract**—*Bird strike- is a very frequent phenomenon. It can cause huge damage for aircraft. Bird strikes may occur during any phase of flight but are most likely during the take-off, initial climb, approach and landing phases due to the greater numbers of birds during flight at lower altitudes.*

**Keywords**—*bird strike; aircraft damage; phases of flight.*

## 1 INTRODUCTION

A bird strike is strictly defined as a collision between a bird and an aircraft which is in flight or on a take-off or landing roll. The term is often expanded to cover other wildlife strikes - with bats or ground animals.

Bird Strike is common and can be a significant threat to aircraft safety. For smaller aircraft, significant damage may be caused to the aircraft structure and all aircraft, especially jet-engine ones, are vulnerable to the loss of thrust which can follow the ingestion of birds into engine air intakes. This has resulted in a number of fatal accidents.

## 2 EFFECTS

The nature of aircraft damage from bird strikes, which is significant enough to create a high risk to continued safe flight, differs according to the size of aircraft. Small, propeller-driven aircraft are most likely to experience the hazardous effects of strikes as structural damage, such as the penetration of flight deck windscreens or damage to control surfaces or the empennage. Larger jet-engined aircraft are most likely to experience the hazardous effects of strikes as the consequences of engine ingestion. Partial or complete loss of control may be the secondary result of either small aircraft structural impact or large aircraft jet engine ingestion. Loss of flight instrument function can be caused by impact effects on the Pitot Static System air intakes which can cause dependent instrument readings to become erroneous.

Complete Engine failure or serious power loss, even on only one engine, may be critical during the take-off phase for aircraft that are not certificated to 'Performance A' standards. In the case of bird ingestion into more than one engine, all aircraft are vulnerable to loss of control. Such hazardous ingestion is infrequent but may result from the penetration of

a large flock of medium sized birds or an encounter with a smaller number of very large ones.

In some cases, especially with smaller fixed wing aircraft and helicopters, windscreen penetration may result in injury to pilots or other persons on board and has sometimes led to loss of control. Although relatively rare, a higher altitude bird strike to a pressurized aircraft can cause structural damage to the aircraft hull which, in turn, can lead to rapid depressurization. A more likely cause of difficulty is impact damage to extended landing gear assemblies in flight, which can lead to sufficient malfunction of brakes or nose gear steering systems to cause directional control problems during a subsequent landing roll. A relatively common but avoidable significant consequence of a bird strike on the take-off roll is a rejected take off decision which is either made after V1 or which is followed by a delayed or incomplete response and which leads to a runway excursion off the end of the departure runway.

## 3 DEFENCES

The primary defence against hazardous bird strikes stems from the requirements for continued safe flight after strikes which are included in the airworthiness requirements of the Aircraft Type and Aircraft Engine Type Certification processes. However, these requirements are not a complete protection and are also mainly focussed on large fixed wing transport aircraft. The relevant design requirements for smaller fixed wing aircraft and helicopters are very limited. The article on Aircraft Certification for Bird Strike Risk provides more detail on this subject.

The opportunities to mitigate the risk of hazardous bird strikes in the first place are centred on airports, because this is where the greatest overall volume of conflict occurs, and because this is where management and control of the hazard is most easily achieved. However, there are two problems with this approach:

1. The airport-centred bird strike risk is rarely confined to the perimeter of any particular airport
2. Many of the most hazardous strike encounters - those with large flocking birds - take place so far from the airport that the airport operating authority will often have little real influence over the circumstances.

Establishing and monitoring levels of bird activity is important and a critical part of this process is the recording

of bird strikes at the local level. This then provides the opportunity to build up larger databases and to share the information.

Guidance on effective measures for establishing whether or not birds, on or near an aerodrome, constitute a potential hazard to aircraft operations, and on methods for discouraging their presence, is given in the ICAO Airport Services Manual, Part 3. Further detail is provided in a number of State-published documents that are useful beyond their jurisdictions and are referred to under Further Reading in the above-mentioned article on Airport Bird Hazard Management.

#### 4 TYPICAL SCENARIOS

1. Bird ingestion to three out of four engines of a departing jet transport occurs at 200 feet alt after take-off has been made despite ATC advice of the presence of large birds and an offer to have them dispersed. As a result, one engine is disabled completely and two others are sufficiently damaged to the extent of only producing reduced thrust. An emergency return to land is made.

2. A flock of medium-sized birds is struck by a jet transport just after  $V_1$  but before  $V_r$  with a rejected take off response despite take off performance being limiting due to aircraft weight. As a result, an overrun occurs with substantial aircraft damage.

3. A twin-engine light aircraft flies into a single heron at 200 feet at ground level after take-off and it breaks through the windscreen and hits the pilot who temporarily loses control so that upon recovery, a forced landing ahead is the only option

4. Wing root damage to a single-engine light aircraft caused by a vulture-strike during climb out causes of structural damage to such an extent that control is lost and terrain influence results.

#### 5 SOLUTIONS

- Habitat management, including reduction or elimination of trees, shrubs and other plants, which provide food, shelter or roosting sites for birds.

- Netting or draining of streams, routinely wet grassland and areas of standing water. Prevention of transient formation of such areas after heavy rainfall.
- Aerodrome grass management appropriate to the prevalent species and the degree of risk that they pose. Grass height maintenance can be very important.
- Liaison with local authorities to ensure that landfill waste disposal sites are not operated so as to create an aircraft hazard.
- Liaison with local farmers to limit the attraction of birds to fields.
- Use of bird scaring techniques such as:
  - Broadcast of bird distress signals;
  - Firing of pyrotechnic bird scaring cartridges.
- Tactical detection of large flocking birds using specialized ground-based radar equipment.



Fig.1. Example of a bird strike

#### SOURCES

- 1 Wikipedia.org
- 2 Skybrary.aero
- 3 Airbus Flight Operations Briefing Note - Birdstrike Threat Awareness

# Psychological Effects of Various Noises on the Crew

Dariia Ovcharenko

scientific adviser: Nataliia Zelinska

Aviation English department,

Educational and Research Institute of Air Navigation, Electronics and Telecommunications,

National Aviation University,

Kyiv, Ukraine

[dashaovcharenkoo.do@gmail.com](mailto:dashaovcharenkoo.do@gmail.com)

**Abstract**—this paper illustrates the influence of different frequencies and levels noises on the psycho-emotional state of the crew (or in general case person). Here are brought some issues which can be useful for understanding the danger of acoustic environment.

**Keywords**—acoustic stress; acoustic environment; physiological responses; spectrum analysis.

## I INTRODUCTION

Human health and performance in safe working environment are key issues for flight and cabin crew as well as for passengers, who additionally demand well-being and comfort in a supportive travel environment.

Until late 2013, the OSHA(Occupational Safety and Health Administration )noise standard (29 CFR 1910.95) did not apply to cabin crew, such that noise-induced hearing loss has been not been monitored or protected in the aircraft environment. The findings of our health survey confirm that noise testing and hearing conservation programs are warranted.

To solve the problematic issues of the effect of various types of noise on the crew, it is proposed to study such a concept as acoustic stress of the "shock" type. Nowadays the ways of preventing the factors that are unfavorable for human being are widely discussed, in some cases that arise in the intensive work of the airport.

## II MAIN PART

Some authors point out that, with a very strong noise effect (120 dB or more), people "may have painful conditions: movement disorders, dizziness, psychosis" The authors point out that in the production environment of the airport such noise is possible in particular near operating turbojet engines. And now we can imagine the danger that arises on the territory of the airport during the work of ground service, whose response on extraneous noise can be quite different.

It has been established that for a certain type of people in CA, at a sufficiently high volume, "shock type" acoustic signals can remain frightening, stressful after a large number of repetitions. Extreme acoustic signals include emotional sounds similar to some biological ones (the cry of a child, the groan of a wounded man, etc.) or even those that are in the subconscious (noises of metal grinding, falling of a heavy object). Now let's imagine a situation when there are noises in the flying aircraft, for some people there can be bad consequences.

## III EXPERIMENTS

It is only possible to change environmental conditions in a real flight within rather restricted limits For obvious reasons. Therefore, tests are designed in a simulator facility, which is tuned to reproduce "real" flight data in virtual reality. Two simulators with certain vicinity to a real aircraft are used (based on parts of an A 320 and an A 300):

One of several experiments is reported now, based on a  $3 \cdot 3 \cdot 3$  full-factorial design: 3 levels of temperature, 3 levels of humidity, 3 levels of sound (including vibration). Each combination is investigated, i.e. 27 different flight situations of 1 hours duration. The experiment is designed as a 3 hour flight (per day) with boarding and de-boarding time, i.e. crew and passengers perceive one flight of about 4 hours (incl. start and landing) without any break. Climate is kept constant during each flight, sound level is very smoothly changed after one hour, respectively. This transition is not perceived subjectively, neither by crew nor by the test supervisors in the simulator. About 100 crew members participated in this test. Table 1 gives the test condition with the absolute range of the parameters as determined within the cabin in the workplace area of the crew (cockpit not included).

Temperature t [°C]	21 – 22	24 – 25	27 – 28
rel. humidity rh [%]	5 – 10	15 – 20	25 – 30
sound level s/v [dB(A)]	70 ± 1	73 ± 1	76 ± 1

Table 1: Target values for parameter selection with actual range in the cabin.

+				-			
t1				t1			
rh1	s/v1	s/v2	s/v3	rh1	s/v3	s/v2	s/v1
rh2	s/v1	s/v2	s/v3	rh2	s/v3	s/v2	s/v1
rh3	s/v1	s/v2	s/v3	rh3	s/v3	s/v2	s/v1
t2				t2			
rh1	s/v1	s/v2	s/v3	rh1	s/v3	s/v2	s/v1
rh2	s/v1	s/v2	s/v3	rh2	s/v3	s/v2	s/v1
rh3	s/v1	s/v2	s/v3	rh3	s/v3	s/v2	s/v1
t3				t3			
rh1	s/v1	s/v2	s/v3	rh1	s/v3	s/v2	s/v1
rh2	s/v1	s/v2	s/v3	rh2	s/v3	s/v2	s/v1
rh3	s/v1	s/v2	s/v3	rh3	s/v3	s/v2	s/v1

Table 2: Parameter combinations: Sound level is either increasing (+) or decreasing (-) during one simulated flight. Each combination lasts for one hour, each row represents one flight.

Table 2 gives the complete series of combination of the three parameter levels including one repetition, summing up to 18 flights. Due to the experimental conditions to become and stay stable after "take-off" it is not possible to randomize the climate conditions. This could be done in principle for the sound level, but is not realized in the present experiment. The order of presentation is therefore an additional environmental parameter. The objective of the  $3 \cdot 3 \cdot 3$  design is to study each mutual interaction of the selected parameters in the human response. The variations in Table 1 reflect the fact that the target values are only provided for certain fixed locations in the

simulator. Real values deviate at different places in the cabin in the indicated way. The target values are adapted to real flight data and do by purpose not include extreme values. The crew members are “wired” to pick up physiological data. During service breaks they have to fill in questionnaires which contain items on :

- health and well-being (30 items);
- environmental conditions (45 items);
- control over environment (8 items) 3/8;
- relative comfort contribution (18 items);
- effect of the environment (18 items);
- ability to work (8 items);
- alertness and mood (9 items).

Since annoyance is obviously related to factors of noise, an analysis is carried out to test for order effects. The perceived annoyance is plotted against the target sound levels separately for the cases of increasing level and decreasing level during one simulated flight. The result is shown in Figure 6. For increasing sound level a significant increase in annoyance to noise is observed (green). But if the order of representation of the same sound levels is reversed, the annoyance is not decreased. This might be due to an increase of annoyance with flight duration, which compensates for the decreasing sound levels.

The range of variables is limited by the physical test facility. A response model is therefore only valid within the given variance of the test set-up. Related to sound and vibration impact, only the level of noise was 6/8 adjusted in the present experiment, the level of vibration was depending on the noise. [1]

Different physiological responses have been identified as the impacts of noise such as a circulatory response dominated by vasoconstriction of peripheral blood vessels affecting blood pressure, heart rate and blood pressure variations, a reduced rate of breathing, galvanic skin response, a reduction in the electrical resistance of the skin, a brief change in the skeletal-muscle tension, hormonal changes, etc. Most of these physiological behaviors within the body are observed to be associated with different frequency characteristics.

Apart from loudness, other characteristics of noise, such as the frequency, duration of exposure, frequency of interruption, and duration of the interruption, become relevant in evaluating the effects of noise. It is observed that frequency-related characteristics of noise, for instance intermittent, irregular, tonal, pulse, etc. generate more annoyance than steady noise of the same intensity. Evaluation of exposed noise and its adverse health effects based on intensity is inadequate, because pathophysiological effects have also been observed at low levels, which impairs auditory functions. Accordingly, inclusion of noise frequency spectrum analysis will yield more insights from evaluation. One of the review studies observes that, with very few exceptions, environmental noise assessments rarely include a frequency spectra analysis. Furthermore, the study indicates that from the past decades, scientific investigation into the extra-aural, whole-body, noise-induced pathology issue has been infrequent, and existing data are often regarded as inconclusive. In the light of the above, it is evident that contribution of frequencies of noise is also important in evaluating adverse health effects; further auditory damage risk and physiological system response of human

system are related to noise frequency. Therefore, frequency spectrum analysis in evaluating health effects due to noise exposure becomes essential.

It is observed that the central auditory system of human body is built on frequency-specific processing channels (tonotopic organization) and thus assessing and characterizing an acoustic environment requires both the dB level and the frequency distribution considerations. This was also supported by Pereira, Branco in the study, which states that assessment of noise effects should consist data of both intensity and frequency spectrum analysis because the frequency range to which whole-body organ systems respond is not the same as that for the auditory system. In other words, different organ systems are susceptible to different acoustic frequencies.

The actual pressure transformation in the human ear depends on the frequency of the acoustic stimulus. The pressure increase between eardrum and inner ear is  $\geq 30$  dB in the region of 2.5 kHz. However, the ratio was observed to decrease at frequencies  $> 2.5$  kHz. Hearing impairment depends on the characteristics of the noise one is exposed to, frequency, in particular. An increase in auditory threshold due to noise exposure, temporary threshold shift (TTS) is different for different frequencies, even though noise level is the same. In general, a more TTS is produced at higher frequencies at least up to 3-6 kHz. Thus, when the exposure is to a broadband noise, a maximum TTS is found at frequencies between 3 and 6 kHz. When the exposure is to a pure tone, the TTS is found to increase as frequency of the exposure tone increases.

Laboratory studies, conducted by Landstrom as reported, evaluated the physiological effects of low-frequency sound with reference to sleep reveals the reduction in wakefulness occurred during a repeating 42 Hz signal at 70 dB, while an increase in wakefulness occurred for a repeating frequency of 1 kHz signal at 30 dB.

Some studies have attempted to describe physiological and psychological effects of noise. These studies discuss the probable symptoms on exposure to various low-frequency noise characteristics. The study elucidates that low-frequency noise (0-500 Hz) acoustic phenomena can affect several organs and tissues, but the effect depends on the frequency of the acoustic event because every organ and tissue has its own acoustic properties.

Experimental studies demonstrated that biological tissue is very sensitive to lower frequencies (below 100 Hz). Specific frequencies have deleterious impacts on specific biological tissues. Hanlon and Errede observed mild nausea, giddiness, and respiration-related effects for the frequency range of 50-100 Hz at 150 dB.[2]

#### IV CONCLUSIONS

As we can see the certain frequencies influence the man's consciousness and psycho-emotional state. That's why we must investigate the sources of this noises and provide the flight crew with necessary equipment to avoid such human factors. There are vibration and noise frequencies which can be controlled. For example, generators, stators, wires and voltage sources create the electromagnetic field, which penetrate into humans' minds and bodies at all. Such equipment radiation level must be checked during manufacturing. These characteristics are very important for not only appropriate aircraft flight performance but also for providing smart and

conscious acts of cabin crew of this aircraft. The noise influences the speed of decision making greatly. It is the most important factor of safe flight management.

#### REFERENCES

[1] The 33rd International Congress and Exposition on Noise Control Engineering, Oldenburg University, Institute for Physics, 26111 Oldenburg, Germany.

[2] <http://www.noiseandhealth.org>

# Client-server program for displaying flight information about fuel temperature

Andrew Tkalia

Supervisor: Voronov S. I., Pershukova O. O.

Department of Aerospace control systems

Institute of Aeronavigation, Electronics and Telecommunications

National Aviation University

Kyiv, Ukraine

anddt@ukr.net

**Abstract** — The work is devoted to the problem of improving the display of flight information on fuel temperature for pilots and flight engineers. The paper proposes software that can display both the instantaneous values of the readings of the sensors and the values of a small length sample using an oscilloscope via the virtual console.

**Keywords** — client, server, local area network, TCP, IP, fuel system, SUIT, temperature, TU-154

## 1 INTRODUCTION

To organize a safe flight, you should always have fresh and reliable information about the fuel temperature in the fuel tanks of the aircraft. Depending on the temperature of the environment and the flight altitude, the physical properties of the fuel, including the kinematic density, change. At low temperatures, crystals will form from fuel, which can cause clogging of pipelines, falling fuel pressure and engine stops.

Therefore, during the flight, especially at high altitudes, we should have information about the temperature of the fuel. In this paper we have figured out the process of receiving and displaying information on fuel temperature in fuel tanks of the Tu-154 aircraft, which, in its fuel system, has a fuel metering control system SUIT4-1T, which in turn contains a temperature sensor P-85<sup>[4]</sup>

## 2 DRIFT

Nowadays, there exists a tendency for virtualization of flight information display panels for pilots and onboard engineers. To solve this problem, appropriate software was developed, which purpose is to collect data from sensors and to visualize it in real time. Software development was conducted in the Delphi 7 development environment. The core of the program is the client-server architecture: the server serves as a simulator of temperature sensors; the client is responsible for displaying data in the graphical console.

The client-server architecture is one of the architectural software templates and is a dominant concept in the creation of distributed network applications and involves interaction and data sharing between them. The architecture includes the following main components:

1. A set of servers that provide information or other services to programs that invoke them;
2. A set of clients that use services provided by servers;
3. A computer network that provides interaction between clients and servers.<sup>[3]</sup>

The program was designed as follows:

The client and server contain services. Services in the server side are simulators of sensors, in the client – virtual consoles for information display. After activation the server waits for connection and commands from client.

The program was developed in the Delphi 7 environment using the Internet Direct (Indy) library. It has the necessary components to work on the network at a high level. The component set is divided into three groups: Indy Client, Indy Servers, and Indy Misc. Most components of Indy Client and Indy Servers are pairs that match the client and server sides of the protocols and services. Thus, the programmer has to implement specialized server logic only.

The TCP Transmission Control Protocol (TCP) was selected as the protocol for data exchange between the client and the server. It is intended for data transfer control in computer networks. TCP operates on the transport level of the OSI model. Unlike another commonly used UDP transport layer protocol, TCP provides reliable data transmission from the sender node to the receiving node. For example, due to the presence of interference in the line, the client may receive a corrupted message from the server or may not receive it at all. In this case, the client will not send a receipt to the server about the successful reception of information, and the server after some time will send a message to the client again.<sup>[3]</sup>

Transport layer (Transport layer) provides applications or upper levels of the OSI stack – application and session – the transfer of data with the degree of reliability that they need. The OSI model defines the five service classes provided by the transport layer. These types of service differ in quality of the services provided: the urgency, the possibility of restoration of the interrupted communication, and most importantly – the ability to detect and correct transmission errors, such as distortion, loss and duplication of packets.<sup>[3]</sup>

The main tasks of the transport level:

1. splitting and numbering of the higher level messages into packages;
2. buffering of accepted packages;
3. arranging of arriving packages;
4. addressing of applied processes;
5. flow control.

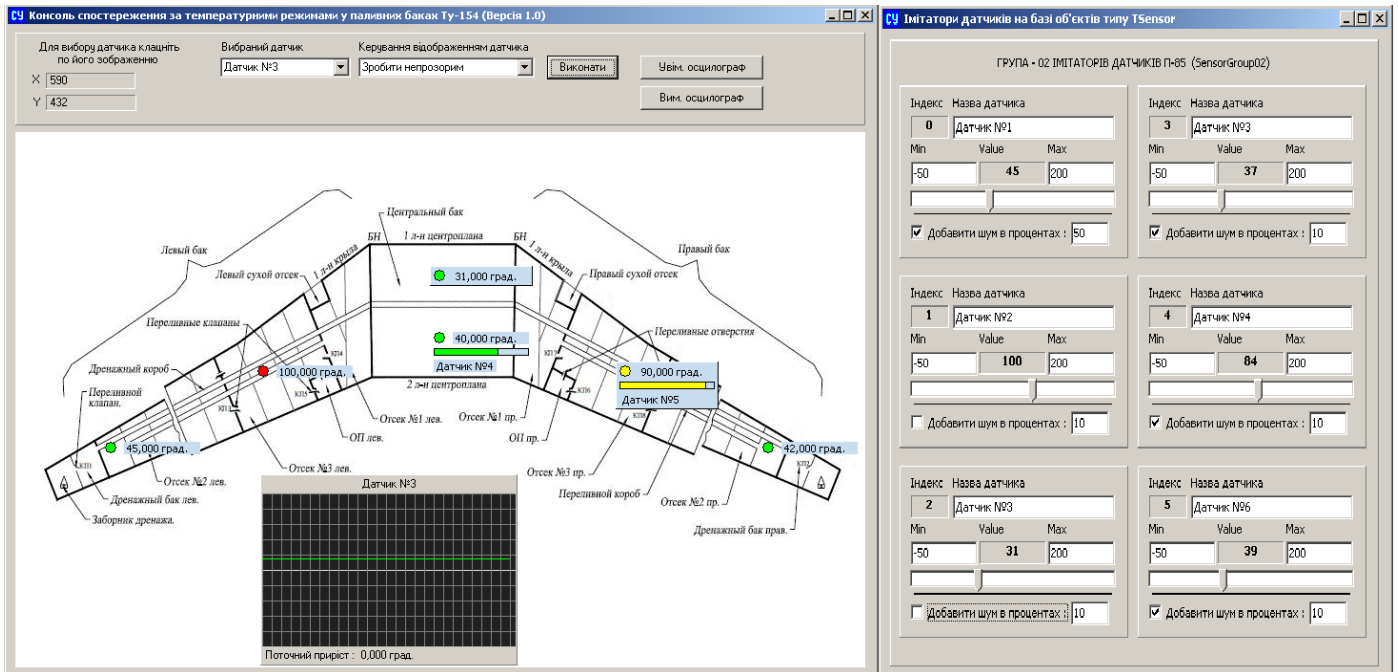

Fig. 1. Demonstration of the client-server architecture capabilities in the implemented software

### 3 CONCLUSIONS

The developed software allows to:

1. Simulate data on fuel temperature in tanks.
2. Visualize of the fuel temperature data in the tanks on the virtual console.

As the software developed is based on the client-server architecture, it is possible to connect multiple clients to one server, that is, to visualize the data on several consoles simultaneously.

Novelty of scientific research can be considered improvement of the method of output information about the temperature of fuel in tanks – displays a window with the scheme of the aircraft, which marked the sensors. The marks change their color depending on the measured temperature.

Foreseeable assumptions about the development of the research object are:

1. Adaptation of the program for use with the airborne computer complex;
2. Replacement of the system of simulators in the server part with real information measuring systems (resistive temperature sensor P-85).

### REFERENCES

1. Иванова Г.С. Основы программирования: Учебник для вузов. - 2-е изд., перераб. и доп. - М.: Изд-во МГТУ им. Н.Э. Баумана, 2002. – 416 с.
2. Н.Культин. Основы программирования в Delphi 7. – СПб: БХВ-Петербург, 2003. – 608 с.
3. Дарахвелидзе П.Г., Марков Е.П. Программирование в Delphi 7. – СПб: БХВ-Петербург, 2003. – 784 с.
4. Авиационное оборудование/Ю. А. Андриевский, Ю. Е. Воскресенский, Ю. П. Доброленский и др.; Под ред. Ю. П. Доброленского. – М.: Воениздат, 1989. – 248 с.



# AMAN and DMAN integration

Hanna Serhieieva, student  
Supervisor: Pershukova O. O.  
National Aviation University, Kyiv, Ukraine  
IAN Student, Group 513  
c. Kiev, st. Kosmonavta Komarova 1  
E-mail: raynihon@gmail.com

**Abstract— Air traffic management involves organization and control the flow of traffic on the ground and in the airspace around the airport in a safe and efficient manner. Typically, it considers two distinct problems: The Arrival Management Problem (AMAN) and the Departure Management Problem (DMAN). As we are faced with the issue of overloading of ATC, so implementation of AMAN and DMAN could significantly simplify our life and allow increase capacity of ATS. Keywords—cooperation, integration, separation, sequencing**

## 1 Introduction

Capacity is one of the major factors that influence on nowadays safety of aviation. As you know the amount of flight increases rapidly and the capacity is the same. So, to provide service for as many flights as possible with the required level of safety we should look through the concept of airspace and implement new strategies and technologies.

In the early 90's it was commonly agreed upon among experts that large European airports would become the bottlenecks of the whole ATM system, if in the light of the forecast increase of air transport the operation of air traffic at airports would not be considerably improved. This assumption has been verified in the meantime by reality.

Arrival and departure management were identified as two key areas, which needed to be improved by introducing decision support tools for ATC controllers at airports.

## 2 Analysis of the latest research

Air traffic management involves organizing and control the flow of traffic on the ground and in the airspace around the airport in a safe and efficient manner. Typically, it considers two distinct problems: The Arrival Management Problem (AMAN) and the Departure Management Problem (DMAN). The AMAN problem involves landing sequencing and ensuring proper separation.

The DMAN problem decides the take-off times and sequences for departing airplanes.

In this article, we will talk about the AMAN DMAN algorithm of operation.

AMAN is the arrival management which sequencing aircraft by the time and allowing Air Traffic Controller do not waist time for construction of queue for landing [ 6 ] .

It accounts the changes of aircraft movement and flight parameters making the queue changes flexible. DMAN is the departure management system. This system allows create queue for departure accounting to the time of start-up engines, time for taxiing and taking off. So, we do not need to create sequence for line up, because the system creates it and we can use calculated data.

But the only problem is their implementation. As you could know, we need detailed plan how to develop the strategy and installation of special equipment. In this article we provide with the algorithm of operation of these two systems.

## 3 AMAN

The AMAN assists the Controllers in the sequencing activity of arrival flights on a given airport. AMAN distributes the workload by improving coordination between ACC and APP and between sectors in ACC and between APP and TWR. AMAN provides a list of SFPLs (Arrival Sequencing List — ASL) in order to ensure a safe separation between two consecutive landings on a constraint point (Initial Approach Fix, aerodrome or runway) and ensures optimum runways utilization and the quickest landing time for aircraft. The AMAN takes into account the SFPL Trajectory, the Environment Data provided by the FDP and the controller orders and provides the Arrival Sequencing List [3].

1. *The AMAN computes the optimized times over the Sector Exit Fixes or TMA Entry Fixes and*

ii. *For author/s of more than two affiliations: To change the default, adjust the template as follows.*

1. *Selection:* Highlight all author and affiliation lines.

2. *Change number of columns:* Select the “Columns” icon from the MS Word Standard toolbar and then select “1 Column” from the selection palette.

3. Highlight author and affiliation lines of affiliation I and copy this selection.

Scheduled Time of Arrival (STA). An Arrival Sequencing List includes all flights whose Expected Time Over (ETO) on a constraint point is less than T minutes (Operational Horizon – between 0 and 300 minutes; typically 60 minutes) from the actual time. Several ASLs can be defined for different constraint point within the Area of Responsibility. In order to assure the right separation among arrival flights, within a given operational horizon, ASL can be automatically or manually updated and automatic advisory are also performed. When a flight lands (reach the constraint

point) or is re-routed to another airport it is automatically deleted from the Arrival Sequencing List [1].

#### IV.DMAN

The departure manager (DMAN) tool takes into account the scheduled departure times, slot constraints, runway constraints and airport factors. In doing so, it improves traffic predictability, cost efficiency and environmental sustainability, as well as safety. By taking into consideration information such as the aircraft's readiness to leave its parking stand, runway capacity and slot constraints, tower controllers can optimize the pre-departure sequence.

In order to calculate reliable sequences, DMAN needs access to accurate information about the status of individual flights and airport resources from different systems. The airport collaborative decision-making (A-CDM) platform supports this information exchange. For example, the airline or ground handler can provide the target off-block time (TOBT), while the tower controller uses tables which generate variable taxi times to achieve the target take-off time (TTOT). Information about departure slots or calculated take-off times (CTOTs) is sourced from the Network Manager, responsible for flow control across the whole of Europe [4].

#### IV. AMAN DMAN BENEFITS

- ❖ Approach planning for defining the approach sequence for the entire area of responsibility of an airport;
- ❖ Arrival management for calculating precisely timed approach paths based on the definitions generated by approach planning, from the point

where aircraft enter the planning area to the runway threshold;

- ❖ Approach monitoring for continuous monitoring of separation between all aircraft in the terminal control area and compliance with the planned 4D approach paths;
- ❖ Improved predictability and stability of departure sequence, start-up approval time and off-time blocks;
- ❖ Enhanced tactical runway scheduling;
- ❖ Reduced waiting and taxi times and runway delays;
- ❖ Significant reduction in fuel burn and CO2 emissions [5].
- ❖ Information management server providing reliable information to all airport stakeholders [2]

### **References**

- [1] EUROCONTROL-AMAN Status Review 2010 Edition Number: 0.1 Edition date: 17 December 2010
- [2] EUROCONTROL - A-AMAN Advanced Arrival Management System
- [3] Dietmar Böhme : TACTICAL DEPARTURE MANAGEMENT WITH THE EUROCONTROL / DLR DMAN , 2000
- [4] EUROCONTROL - SESAR Solution Regulatory Overview DMAN Baseline to be used for Integration of AMAN and DMAN, Edition 01.02.00
- [5] EUROCONTROL - Coupled AMAN-DMAN, Edition 00.01.00, 2011
- [6] EUROCONTROL - Arrival Manager, Edition Number: 0.1 Edition date: 17 December 2010
- [7] EUROCONTROL - SESAR Solution DMAN Baseline to be used for Integration of AMAN and DMAN , 2011

# Aircraft Equipped with Solar Panels

Dmytro Syritso

scientific advisor: Nataliia Zelinska

Aviation English department,

Educational and Research Institute of Air Navigation, Electronics and Telecommunications,

National Aviation University,

Kyiv, Ukraine

[syrtisodmitriy@gmail.com](mailto:syrtisodmitriy@gmail.com)

**Abstract**—*The paper is dedicated to the aircraft power consumption and methods of the alternative energy sources use in aviation. Solar energy can be successfully utilized for unmanned aircraft operation.*

**Keyterms**—*solar energy; aircraft engine; unmanned aircraft; environmentally friendly technologies; aviation fuel.*

## I INTRODUCTION

An electric aircraft is an aircraft powered by electric motors. Electricity may be supplied by a variety of methods including batteries, ground power cables, solar cells, ultracapacitors, fuel cells and power beaming.

## II THE ERA OF SOLAR ENERGY

Electric engines on aircraft were used in the XIX century. On October 8, 1883, the first flight was made by the French aeronaut Gaston Tissandier on the airship La France equipped by the electric motor of Werner von Siemens fed by a 435-kilogram battery. The launches of electric fixed-wing aircraft models have been carried out since 1957, but there are unconfirmed reports on the launch in 1909. Electric models were inferior in speed to models flying on liquid fuels which were more expensive.

The main drawback was the lack of capacious batteries, and therefore the wide distribution of the electric model was received only in the early 1990s. A significant rush in this area of aircraft production was in the late 1990's - early 2000's, when the creation of electric aircraft interested private companies.

Among the reasons that contributed to the development of a new type of aircraft there were the increased requirements for environmental protection, the emergence of modern capacious batteries, as well as lightweight and durable materials.

Among other things, electric aircraft are distinguished by a low noise level, which can be a good advantage when performing reconnaissance operations. A world record was also established for the duration of a manned flight for solar-powered aircraft - 26 hours. 12 thousand solar cells charge the batteries during the day. This amount of energy is enough to fly at night, so a single aircraft can theoretically be in the air for as long time as you want. In addition to the energy stored in the

batteries, the airplane being used for the flight at night uses the height gained during the day.

Also the creation of hybrid aircraft is possible by analogy with hybrid cars, where one type of engines can be used for take-off, and another one - for the flight. Now we can fly without fuel longer than with fuel, and fly with the help of the forces of nature, fly with help of sun energy.

## III THE CAPABILITIES OF SOLAR ENERGY

British unmanned aircraft QinetiQ Zephyr powered by solar panels in 2010 set a world record of the duration of Unmanned aerial vehicle flight, having been in the air for two weeks.

On June 28, in 2016, The Facebook conducted a trial start of an unmanned Aquila solar-powered airplane designed to distribute the Internet to residents of remote areas. According to Mark Zuckerberg's information, such devices can be carried out in flight up to several months at an altitude of 18 kilometers. The company plans to create a fleet of similar drones.

Solar power is still at the very beginning of the path. Its contribution to total world energy consumption does not exceed 0.1%, and among renewable sources it owns about 1%.

## IV CONCLUSIONS

Due to the technical progress achieved in this field over the past decade, I think that by the middle of the 21st century, solar energy along with other renewable sources (geothermal and tidal stations, wind turbines, etc.) can take the leading position in the world. Consumption of renewable energy sources (without hydroelectric power) increased by 53 million tons of oil equivalent last year, or by 14.1%.

This is a new era of energetics, and this is something that we really should develop. Environmentally friendly technologies nowadays give us incredible opportunities.

## I. REFERENCES

- [1] Olindo Isabella, Klaus Jäger. Solar Energy: The Physics and Engineering of Photovoltaic Conversion, Technologies and Systems
- [2] [https://en.wikipedia.org/wiki/Solar\\_Impulse](https://en.wikipedia.org/wiki/Solar_Impulse)
- [3] [https://en.wikipedia.org/wiki/Solar\\_energy](https://en.wikipedia.org/wiki/Solar_energy)
- [4] [https://en.wikipedia.org/wiki/Solar\\_power](https://en.wikipedia.org/wiki/Solar_power)

# Digital television systems development

Alexander Vinogradov  
scientific adviser: Nataliia Zelinska  
Aviation English department,  
Educational and Research Institute of Air Navigation,  
Electronics and Telecommunications,  
National Aviation University,  
Kyiv, Ukraine  
[alexandervinogradov1997@gmail.com](mailto:alexandervinogradov1997@gmail.com)

**Abstract – This paper is dedicated to the development of digital television systems. There is an explanation of digital television terms, the history of its creation, digital television basic scheme operation and its future trends of use.**

**Keywords – coder, decoder, modulation binary code.**

## I. INTRODUCTION

With the development of the information transmission on long distances the first analogue television (TV) started to develop too. But technologies are always in progress and amount of information, which is needed to transmit, is increasing. In addition, engineers of those days faced with problem information distortion and with quality losses. That is why the branch of digital technologies started to develop.

Digital television (DTV) is the transmission of television signals, including the sound channel, using digital encoding, in contrast to the earlier television technology, analog television, in which the video and audio are carried by analog signals. It is an innovative advance that represents the first significant evolution in television technology since color television in the 1950s[1].

Digital TV makes more economical use of scarce radio spectrum space; it can transmit multiple channels in the same bandwidth occupied by a single channel of analog television, and provides many new features that analog television cannot. A switchover from analog to digital broadcasting began around 2006 in some countries, and many industrial countries have now completed the changeover, while other countries are in various stages of adaptation.

## II. HISTORY

Digital TV's roots have been tied very closely to the availability of inexpensive, high performance computers. It wasn't until the 1990s that digital TV became a real possibility.

In the mid-1980s, as Japanese consumer electronics firms forged ahead with the development of HDTV technology, and as the MUSE analog format was proposed by NHK, a Japanese company, Japanese advancements were seen as pacesetters that threatened to eclipse U.S. electronics

companies. Until June 1990, the Japanese MUSE standard—based on an analog system—was the front-runner among the more than 23 different technical concepts under consideration. Then, an American company, General Instrument, demonstrated the feasibility of a digital television signal. This breakthrough was of such significance that the FCC was persuaded to delay its decision on an ATV standard until a digitally based standard could be developed.

In March 1990, when it became clear that a digital standard was feasible, the FCC made a number of critical decisions. First, the Commission declared that the new ATV standard must be more than an enhanced analog signal, but be able to provide a genuine HDTV signal with at least twice the resolution of existing television images. Then, to ensure that viewers who did not wish to buy a new digital television set could continue to receive conventional television broadcasts, it dictated that the new ATV standard must be capable of being "simulcast" on different channels. The new ATV standard also allowed the new DTV signal to be based on entirely new design principles. Although incompatible with the existing NTSC standard, the new DTV standard would be able to incorporate many improvements.

The final standard adopted by the FCC did not require a single standard for scanning formats, aspect ratios, or lines of resolution. This outcome resulted from a dispute between the consumer electronics industry (joined by some broadcasters) and the computer industry (joined by the film industry and some public interest groups) over which of the two scanning processes—interlaced or progressive—is superior. Interlaced scanning, which is used in televisions worldwide, scans even-numbered lines first, then odd-numbered ones. Progressive scanning, which is the format used in computers, scans lines in sequences, from top to bottom. The computer industry argued that progressive scanning is superior because it does not "flicker" in the manner of interlaced scanning. It also argued that progressive scanning enables easier connections with the Internet, and is more cheaply converted to interlaced formats than vice versa. The film industry also supported progressive scanning because it offers a more efficient means of converting filmed programming into digital formats. For their part, the consumer electronics industry and broadcasters argued that interlaced

scanning was the only technology that could transmit the highest quality pictures then (and currently) feasible, i.e., 1,080 lines per picture and 1,920 pixels per line. Broadcasters also favored interlaced scanning because their vast archive of interlaced programming is not readily compatible with a progressive format.[2]

### III. PROBLEMS OF DEVELOPMENT

The main problem in DTV and digital systems development is necessity of analogue systems, because analogue TV systems is widespread and they has maximum progress nowadays. So, modern DTV systems are some kind of digital devices and analogue systems “symbiosis”.

Also DTV systems have one considerable disadvantage which is called delay. It can be shown up as a freezing and breakdown of picture on the “squares” when the level of signal is not enough.

### IV. MAIN PART

The main features of DVB systems are:

- 1) Essential retraction of frequency band of DTV signal, which we can get in the case of effective coding. This coding can give transmission of 4 or more programs of normal quality, 1 or 2 programs of high quality by the standard TV channel with 6-8MHz frequency bandwidth
- 2) One way of coding and transmission of TV signals with different image quality.
- 3) Integration with other kinds of information when it transmits by digital networks.
- 4) Providing TV programs protection and other information from hacking.
- 5) High noise immunity.

Let’s consider the scheme of DTV system, shown on the figure 2.1

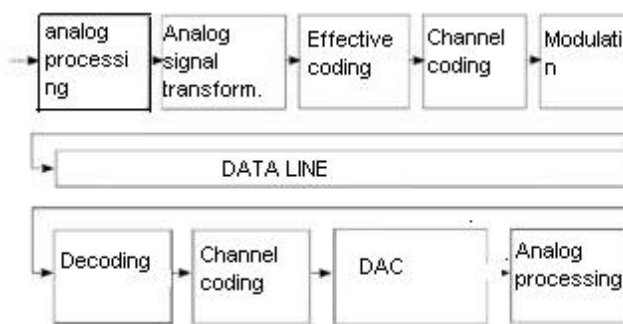

Figure 2.1 Structural scheme of DTV system

An analogue TV signal comes into the input digital TV tract. In the analogue processing block luminance signal and color-difference signal formation, gamma correction and pre-filtering with the purpose of frequency

bandwidth retraction take place. Then analogue signal comes to coder. Coding process consists of 3 stages: discretization in time, quantization by level and representing of each sample in binary code.

These operations are realized by analog to digital converter (ADC). We have series of digits from the output of ADC, which are generated by n-bit binary code. Such coding method is called Pulse Code Modulation (PCM).

Main digital processing proceeds in effective coding block, which realize retraction of digital flow size. Without it we can’t provide DTV signal transmission by the standard channel. Coding of digital video signal can be separated and direct. If all TV signals before transformation in digital signal split on the luminance signal and color-difference signal and each of the components processed independently, then such coding is called separate one. If all TV signals transform into digital signal without splitting, such coding is called direct one.

Effective coding is used for decreasing message length without information losses. This coding is also called statistical because during the code formation statistical (probabilistical) characteristics of information source are taken into account.

Audio signals also transform into digital format. Sound information is compressed in audio coder. Coded image and sound data and different additional information united in multiplexor into one digital flow. A coder accomplishes additional coding with the purpose of noise immunity increase in data line. As a result this digital signal modulates carrier frequency of a channel. In the receiving part demodulation of received high frequency signal and decoding of a channel coding is performed. Then data flow splits on the image and sound data and other additional information in demultiplexor. After that data decoding proceeds. As a result on the decoder output we can get luminance and color-difference signals in digital form. They transform into analogue form with the help of digital to analog converter (DAC) and then they are shown on the monitor. [3]

### V CONCLUSIONS

Nowadays the analogue television goes on the backyard and DTV standards take their place among television systems. But analogue systems are still very important for signal transmission, because all transmitters are analogue by nature. So, we can’t just simply refuse the use of the systems. It would hardly be fully replaced in the nearest future.

### VI. REFERENCES

[1] Kruger, L. G. (2001). Digital Television: An Overview. Hauppauge, New York: Nova Publishers.  
 [2] en.wikipedia.org/wiki/Digital\_television#cite\_note-2  
 [3] Основи телебачення А.Д. Медведик Издательство АО БАХБА

# Emotional Stress Impact on Flight Crew during Emergency Situations

Yurii Vitruck

scientific advisor: Nataliia Zelinska

Aviation English department,

Educational and Research Institute of Air Navigation, Electronics and Telecommunications,

National Aviation University,

Kyiv, Ukraine

[vitruck.yura@gmail.com](mailto:vitruck.yura@gmail.com)

**Abstract**—*The paper is dedicated to the study of optimizing the parameters and characteristics of the impact of various types of stress with the aim of proposing practical calculations of the basic information criteria for expanding the possibilities for their identification. The task can be solved with the help of modern computer technologies.*

**Keywords**—*flight crew; emotional stress; stress impact; emergency situations.*

## 3 MAIN PART

It was noted that during the liquidation of the critical situation, all the pilots stopped responding to the experimenter's questions, which they did according to the flight task before it occurred. Nevertheless, in particularly adverse circumstances, some pilots are not prepared for overcoming difficulties; emotional tension can become immeasurable and play only a negative role. In this situation, at first, mental activity becomes more difficult, there is a narrowing of the amount of attention, stiffness of movements, erroneous actions. Extreme manifestations of emotional tension create disorganization of activity - mental stress. In the most severe cases, there is no action as a result of the shock state.

[3] When analyzing the stressors for a correct prediction of the spectrum of their actions, one must take into account the set of factors characterizing them. The main ones are:

- 1) subjective assessment of the danger of a stressor for the integrity of the subject;
- 2) subjective sensitivity to the stressor;
- 3) the degree of surprise of the stressor.

As it was mentioned above, we can conclude that under stress, perception and thinking are most violated. This is because actions in emergency conditions make the highest demands on these mental processes. To stimulate the formation of mental stability in the pilot, you need to have information about the essential patterns of his behavior in an emergency situation, master the structure of his actions; to study the causes of errors, to study the factors that provoke the growth of tension. In this direction, aviation doctors and psychologists have done a lot of work. In particular, the specifics of the actions of pilots in emergency situations related to equipment failures are thoroughly studied.

## 1 INTRODUCTION

[1] The emotional sphere of a human is a special class of mental processes and states that reflect the immediate experiences of the individual and affect his behavior and activities. A special role here is given to emotional states characterized by high emotional stress. It includes the state of stress. In psychology, stress is understood as a state of mental stress arising in a person in the process of activity under the most difficult conditions, both in daily life and under special extreme conditions.

At present, stress has become quite a common process, which is associated with increased mortality, environmental situation, alcoholism, and the problem of drug use. Consequently, stress has a serious impact on the physical and mental health of a person. But it should be noted that human behavior under stress is not completely reduced to the unconscious level. Constriction of consciousness with affect and stress does not mean its complete frustration.

## 2 THE STATEMENT

[2] The occurrence of emergency situations in flight, often accompanied by increased emotional tension is associated with a direct threat of an accident, and with difficulties in establishing the nature of the emergency situation and making a decision. In an overwhelming number of cases, the tension is not immeasurable, since the change in the pilot's condition is determined, basically, by an increase in the body's readiness for hard work. In this case, there is an increase in muscle tone, increased blood circulation, and, in addition, re-tuning the activity of the sensory organs.

## REFERENCES

- [1] <https://studfiles.net/preview/6223976/page:4/>
- [2] <http://www.physiologynorma.ru/professiya-letchik/psixologicheskoe-vozdejstvie-avarijnoj-situacii-na-letchika/>
- [3] [http://studbooks.net/2449096/tehnika/stress\\_vliyanie\\_deyatelnost\\_operator](http://studbooks.net/2449096/tehnika/stress_vliyanie_deyatelnost_operator)